

Guidelines
and Space Standards for
Barrier Free Built Environment
For
Disabled And Elderly Persons

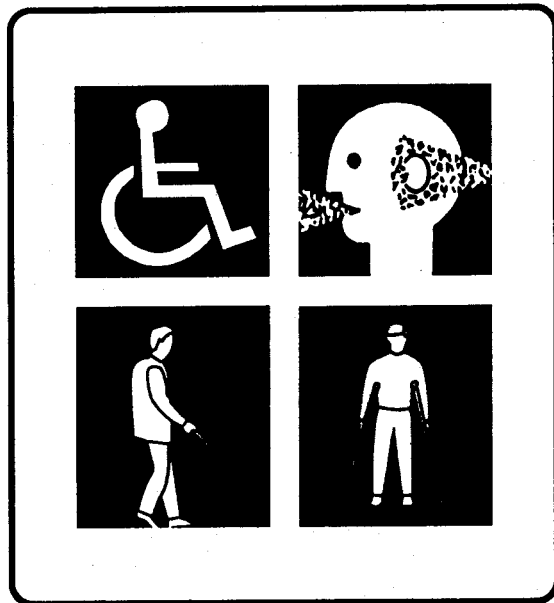

CPWD

Central Public Works Department
Ministry of Urban Affairs & Employment
India
1998

Preamble

The main objectives of the "Persons with Disabilities (Equal Opportunities, Protection of Rights and Full Participation) Act, 1996 enacted by the Government of India on January 1, 1996 are to create barrier free environment for persons with disabilities and to make special provisions for the integration of persons with disabilities into the social mainstream.

Chapter VII of the Act, Sections 44 to 46 deal with non-discrimination in transport on the roads and in the built environment. It enjoins upon the governments and local authorities to ensure within their economic capacity provision for installation of auditory signals at red lights in the public roads for the benefit of persons with visual handicaps, kerbs and slopes to be made in pavements for the easy access of wheel chair users, devising appropriate symbols of disability and warning signals at appropriate places.

In regard to non-discrimination in the built environment, provisions have been made in this Act for ramps in public buildings, adaptation of toilets for wheel chair users, Braille symbols and auditory signals in elevators.

In order to create a barrier free environment in consonance with the provisions of the Act, the Government of India (Ministry of Urban Affairs & Employment) is currently engaged in the process of amending/modifying the existing building bye-laws which would be applicable to all buildings and facilities used by the public.

With this intention to ensure that everyone, including the physically disabled and elderly persons, will have equal access in every day life in the city, the Min. of UA&E has constituted a committee under the chairmanship of DG(W), CPWD with the following members for the purpose of developing comprehensive Guide lines and space Standards for barrier free built environment for disabled and elderly persons.

- | | |
|-----------------------------------|-----------------|
| 1. Director General (Works), CPWD | Chairman |
| 2. Chief Architect I, CPWD | Member Convener |
| 3. Chief Planner, TCPO | Member |
| 4. Chief Architect, DDA | Member |
| 5. Chief Architect, MCD | Member |
| 6. Chief Engineer, MCD | Member |

The access standards codes have taken into consideration the access needs of diverse disability groups, such as persons with mobility, speech, hearing, and visual impairments by meeting disabled peoples standards for safety, convenience and usability.

This "Guidelines and space standards for Barrier Free Built Environment for Disabled and Elderly Person" have also considered the comments received from School of Planning and Architecture (SPA) CBRI, Handicapped Welfare Federation (NGO) and National Federation of Blind (NGO).

The scopes and responsibilities which have been identified in various organisations will include the followings:

ACADEMIC INSTITUTIONS

- * There should be a conscious attempt of all educationists to develop young architects/planners with an awareness of creating barrier free environment for physically handicapped.
- * A detail design exercise should be carried out in all schools of Architecture in their curriculums as an essential subject of architecture education.

STATE GOVT./CENTRAL GOVT. AGENCIES

- * The Govt. departments should follow the recommended standards of provisions for disabled alongwith the general guidelines.

MUNICIPAL BODIES/CORPORATIONS

- * The building codes should specify basic architectural provisions that need to be incorporated in new buildings to make them convenient for disabled.
- * An integrated effort should also require from all local authorities to update their building codes.
- * Municipal authorities/corporations should ensure, before giving permissions of construction, the provisions of stepless system for easy access to buildings, lifts for free access to upper floors, adequate doors width for wheel chairs entry and accessible toilets.

Contents

	Page No.
1. Introduction	5
2. Type of Disabilities	6
3. Mobility Devices	7
4. Controls	11
5. Construction and Maintenance Standards	13
6. Classification of Buildings	17
7. Minimum Access Provisions required in various types of buildings	19
8. Design Elements within the Building Premises (Public Buildings)	21
9. Guiding/Warning floor Material	46
10. Other Facilities	49
11. Design Elements out-side the Building	50
12. Residential Buildings	57
13. Auditorium	66
14. Parks	68
15. Restaurant	70
16. Railway Stations	71

Model Building bye Laws

Annexure-A

Introduction

Barrier Free Environment is one which enables people with disabilities to move about safely and freely and to use the facilities within the built environment. The goal of barrier free design is to provide an environment that supports the independent functioning of individuals so that they can get to, and participate without assistance, in every day activities such as procurement of goods and services, community living, employment, and leisure. The fundamental principles which have been followed in developing standards / norms for various facilities to meet disabled people's standards for safety, convenience and usability. Barrier free design standards should satisfy anyone who is hampered in his mobility or functioning (as compared with a non-disabled person) as a result of obstacles put in his way by the design of a building, the choice of hardware and equipment, and the arrangement of outside space.

The primary objective of this report is to frame guidelines for non-ambulant (chair bound), semi-ambulant (lower limb impairments), visual, and hearing disabled persons. This construction and maintenance standard should be followed in all categories of buildings and facilities used by the public for making accessible to and functional for physically disabled persons. Although the recommendations are concerned exclusively with the requirements of disabled people but the facilities will invariably make buildings more convenient for elderly persons and persons suffering from any kind of physical ailments. A safer, easier environment for

the physically disabled benefits everyone. The main purpose is to integrate disabled and elderly persons fully into the society. The presumption that all elderly are handicapped, or that all handicapped are elderly, is an over simplification of the needs of both groups and is a disservice to both.

Building types to which the recommendations may be applied for are residential buildings other than domestic buildings, commercial buildings, industrial buildings, health care institutions, educational establishments, community and religious centres agricultural and transport facilities. The guide lines have also indicated the minimum access provisions required in various types of buildings.

Builders, designers, and architects and architects are ultimately the users of this standard to ensure the specific environment created by them are suitable for all categories of people. The standard also indicates that barrier free design can be achieved without economic burden to the client, builder, designer, and the architect. It will help to provide framework for developing policies to ensure a barrier free environment and eliminate the lack of awareness in both the public and private sectors to the problem of accessibility. This standard shall be a valuable document to exchange comments between disabled consumers architects and others interested in an environment which does not exclude disabled people. This may also generate research activities to provide required knowledge base.

Type of Disabilities

Various, disabilities which have been considered while preparing the guidelines for barrier free built environment are broadly classified under four categories

1. Non-Ambulatory : Impairments that, regardless of cause or manifestation, for all practical purposes, confine individuals to wheel & chairs.



2. Semi-Ambulatory : Impairments that cause individuals to walk with difficulty or insecurity. Individual using braces or crutches, amputees, arthritics, spastics & those with pulmonary & cardiac ills may be semi-ambulatory.

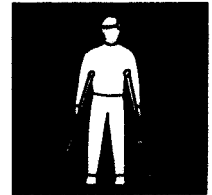

3. Sight : Total blindness or impairments affecting sight to the extent that the individual functioning in public areas is insecure or exposed to danger.

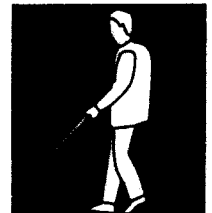

4. Hearing : Deafness or hearing handicaps that might make an individual insecure in public areas because he is unable to communicate or hear warning signals.



Mobility Devices

RECOMMENDATION:

Adequate space for persons using mobility devices

- * Adequate space should be allocated for persons using mobility devices, e.g. wheelchairs, crutches and walkers, as well as those walking with the assistance of other persons (Fig. 1, 2 and 7).
- * The range of reach (forward and side; with or without obstruction) of a person in a wheelchair should be taken into consideration (Fig. 3, 4, 5 and 6).
- * Attention should be given to dimensions of wheelchairs used locally. Standard size of wheel chair has been taken as 1050mm x 750mm (as per ISI).

WHEEL CHAIR

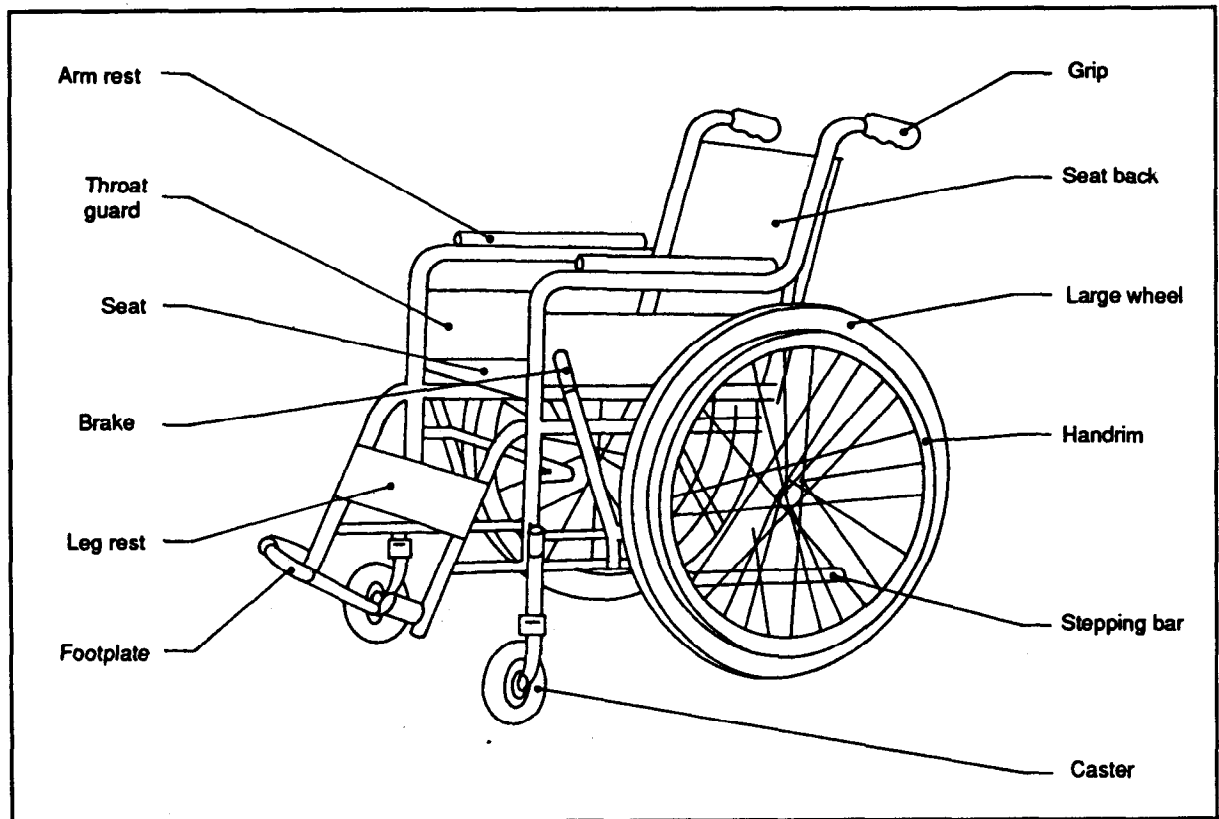

Structure of wheelchair and name of each part (standard type)

Reference Figures

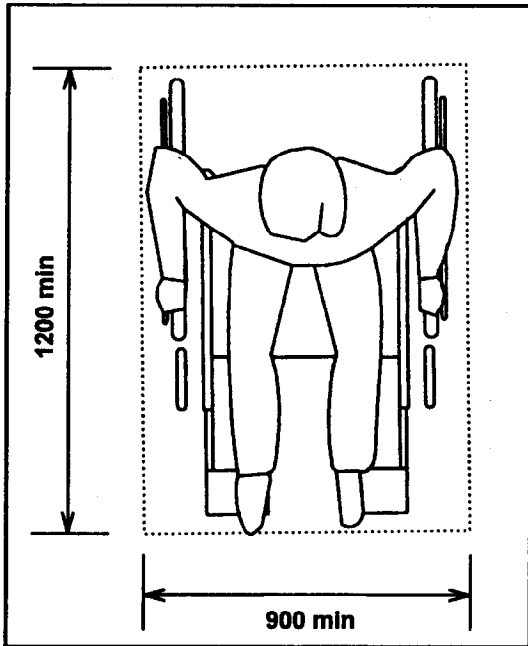

Fig.-1. Space Allowance

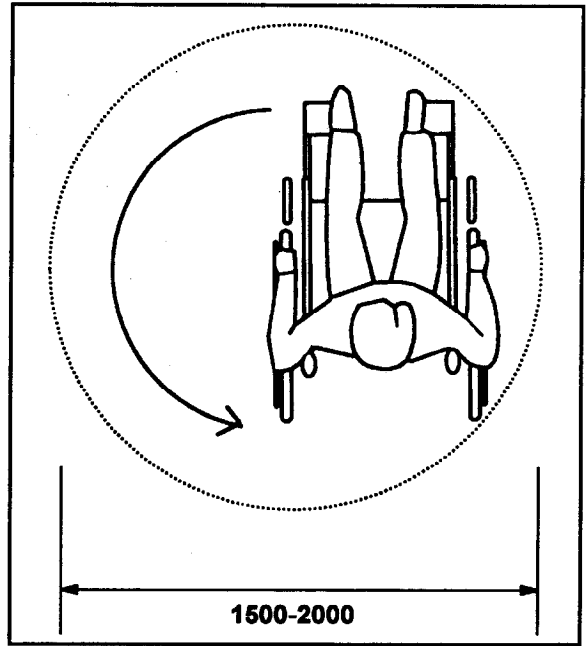

Fig.-2. Space Allowance

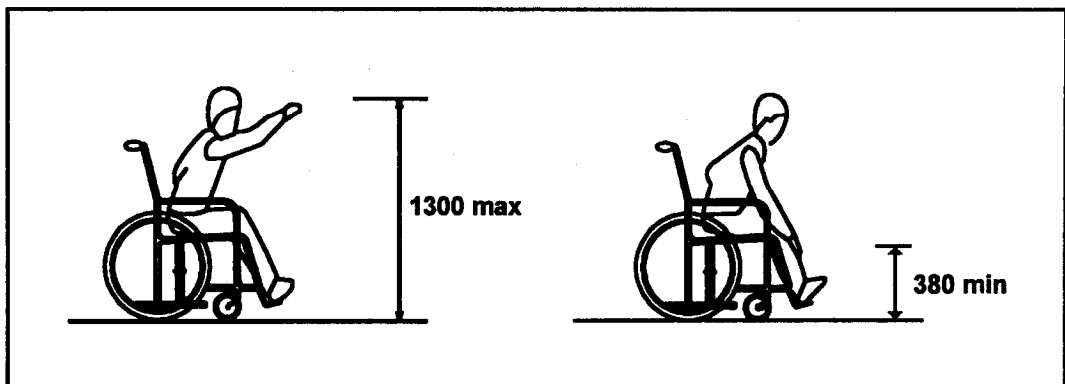

Fig.-3. Forward reach without obstruction

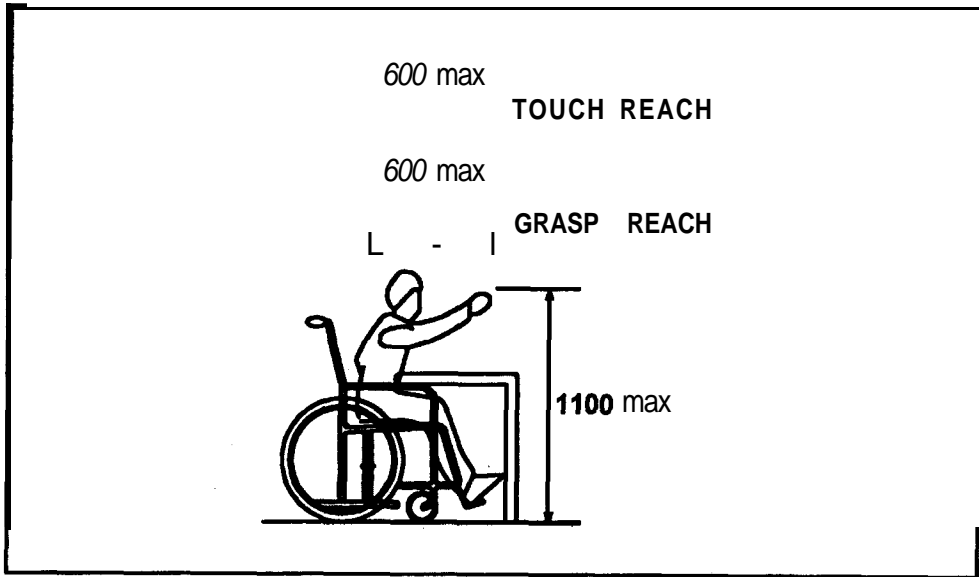

Fig.-4. Forward reach over obstruction

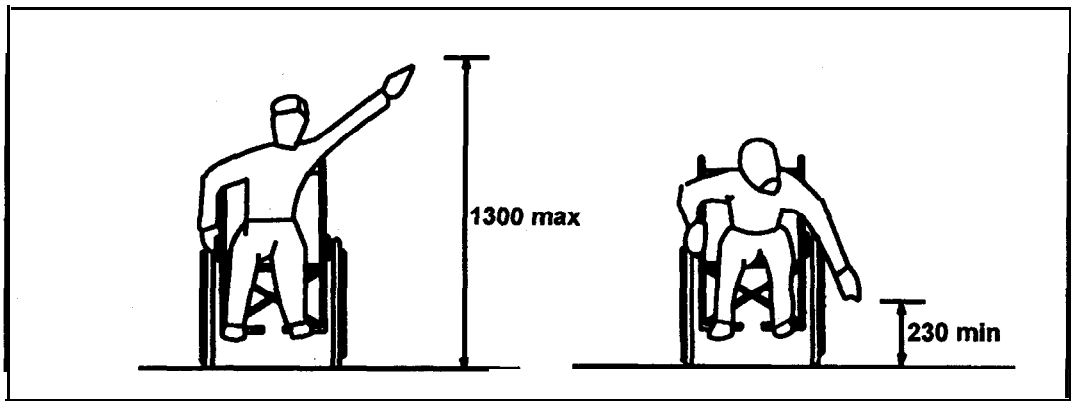

Fig.-5. Side reach without obstruction

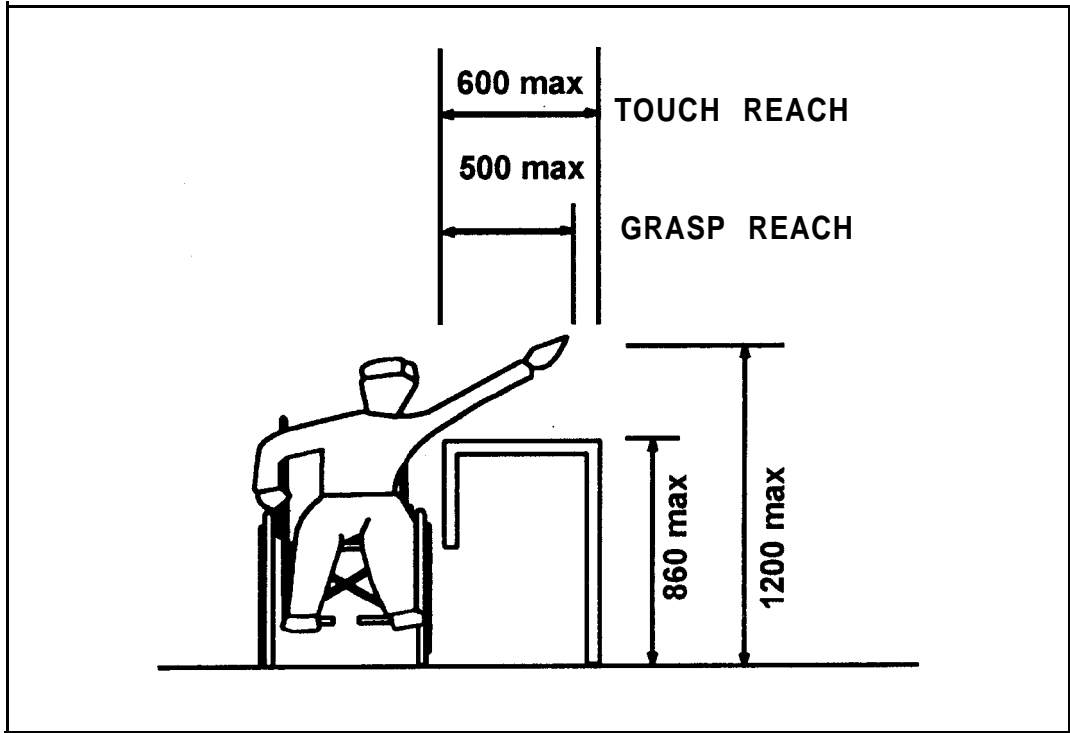

Fig.-6. Side reach over obstruction

CRUTCHES

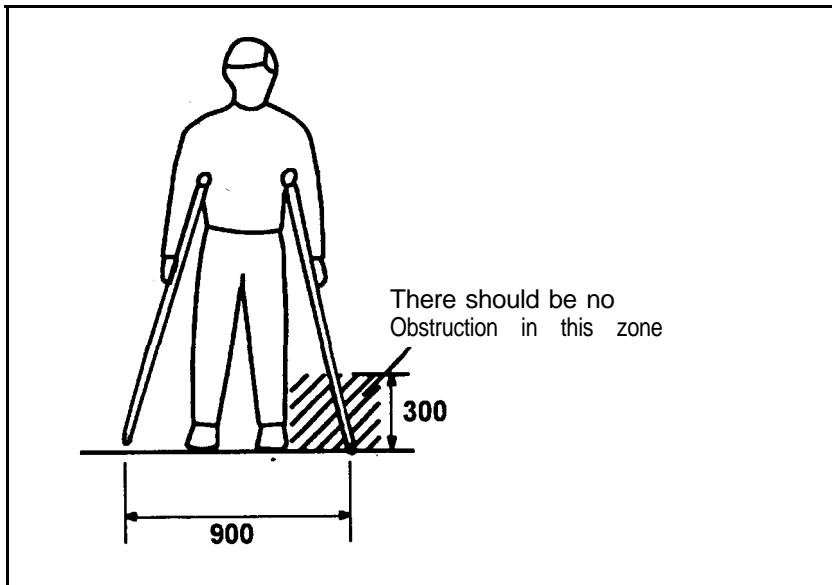

Fig. -7. Space Allowance,

Controls

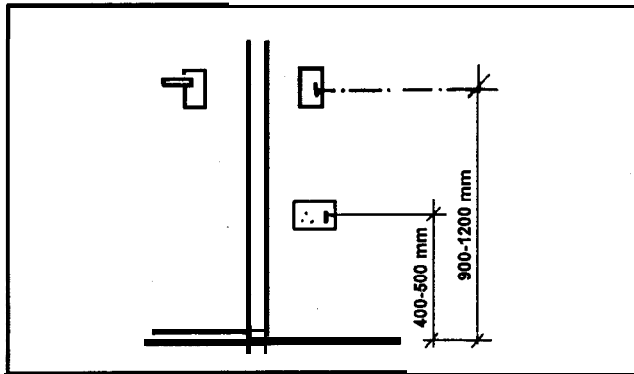

Fig. -8. Heights For Switches, Doors, Handrails

CONTROLS

- * For locking and opening controls for window and doors should not be more than 1400mm from the finished floor usable by one hand.
- * Switches for electric light and power as well as door handles and other fixtures and fittings should be between 900 mm - 1200 mm from finished floor.
- * Power point for general purpose should be fixed between 400-500 mm from the finished floor.

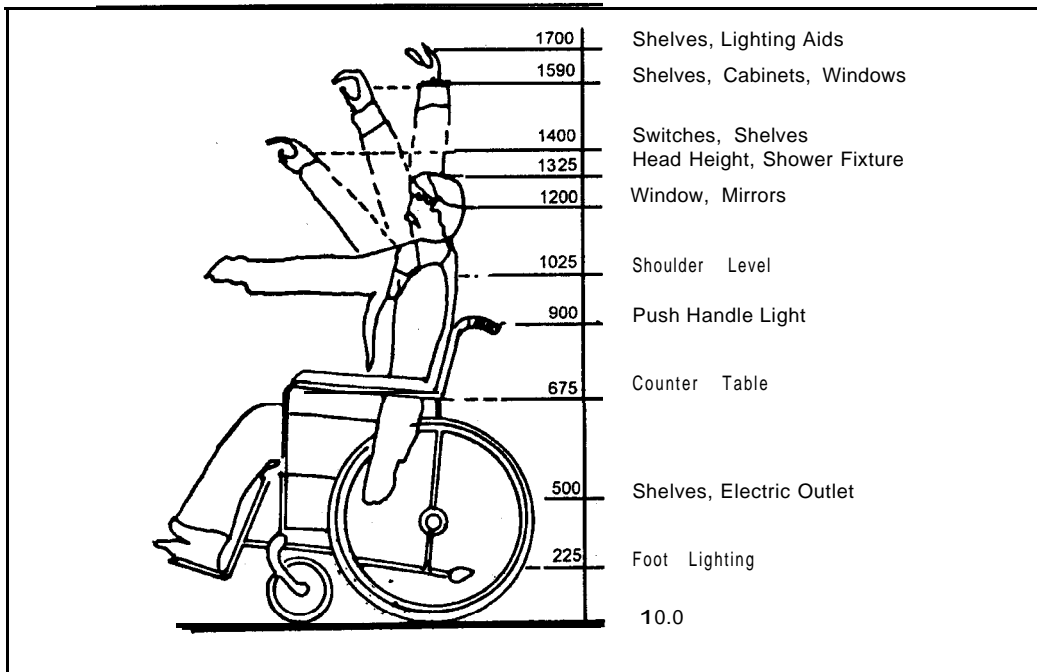

Fig.-9. Typical Dimensions for Essential uses with in easy reach

RANGE OF REACH

- * A wheelchair user's movement pivots around his or her shoulders. Therefore, the range of reach is limited, approximately 630 mm for an adult male.
- * While sitting in a wheelchair, the height of the eyes from the floor is about 1190 mm for an adult male.

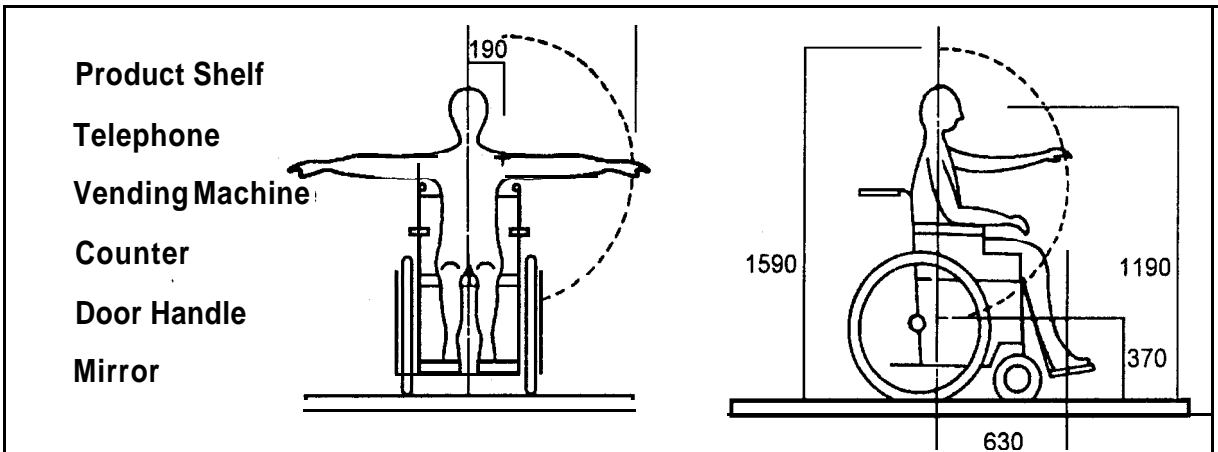

Fig. - 10. Range of Reach

- * A wheelchair has a footplate and leg rest attached in front of the seat. (The footplate extends about 350 mm in front of the knee). The footplate may prevent a wheelchair user from getting close enough to an object.
- Manually operated equipment must be designed to be easily accessible from a wheelchair.
 - Make sure that the coin slots of vending machines etc. are located no higher than 1200 mm.
 - Allow a space at least 350 mm deep and 700 mm high under a counter, stand, etc.

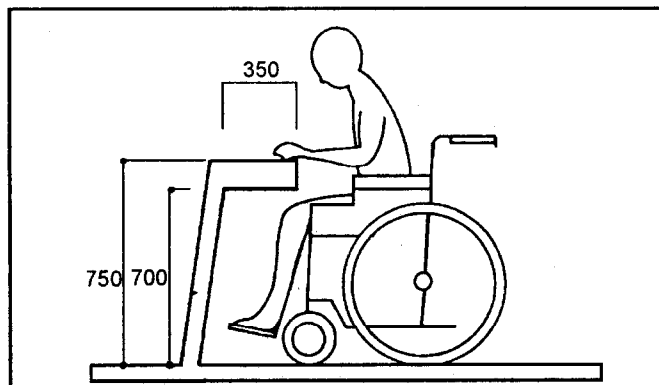

Fig. 11 Space required for wheelchair footplate

Construction and Maintenance Standards

SPECIAL NEEDS FOR THE PERSONS WITH DISABILITIES:-

With regard to the design guidelines the special needs of the persons with disabilities for construction of built environment are as follows.

A. NON-AMBULATORY DISABILITIES

Persons restricted on wheel chair should use the facilities within the built environment alone without a helper's assistance.

Wheelchair Users

A wheelchair may be operated by the user alone or with a helper's assistance. However, wheelchair design must assume that the user should be able to operate the wheelchair without help.

The width and length of the wheel chair, its control and the diameter of the casters decide the following:

- * Width of entrances and exists (clear 900mm, Ref. Entrance / Exit Door Page No. 34)
- * Width of the passage / corridor (min. 900mm Ref. Corridor Page No. 31)
- * Slope of the climbing (min. ramp slope 1:12, Ref. Ramp Details Page No. 29)
- * Passing over different levels and grooves (Grating with narrow slots in the direction of movement and level difference to limit to 2cm or less, Ref. Site Planning, Page No. 22 & 23)
- * Range of reach (Ref. Page No. 12)
- * Transferring from wheel chair (adequate space is required to transfer from wheel chair to toilet seat and bed. (Ref. details of toilet, and guest rooms, Page No.43 & 65).
- * Lift size (Ref. details of lift, Page No. 39).
- * Toilet size (Ref. details of toilet, Page No. 43)

B. SEMI-AMBULATORY DISABILITIES

Persons with impaired walking

Persons in this category who use walking aids such as crutches or canes, who are amputees, who have chest ailments or heart disease. The persons in this category include those who can not walk without a cane and those who have some trouble in their upper or lower limbs although they can walk unassisted.

Design requirements

- * Width of passage for crutch users (min. 900 mm)
- * Finishes of floor surface with non slip floor material.
- * Installation of handrail to support the body weight at the critical places e.g. staircase, toilet, ramp, passage with a change of level (800-850 mm).
- * Extension of handrail on the flat landing at the top and bottom of the stairs (300 mm).
- * To prevent slipping off the cane or crutch from the side of the stairs or ramps (20 mm high lip on the exposed edge).

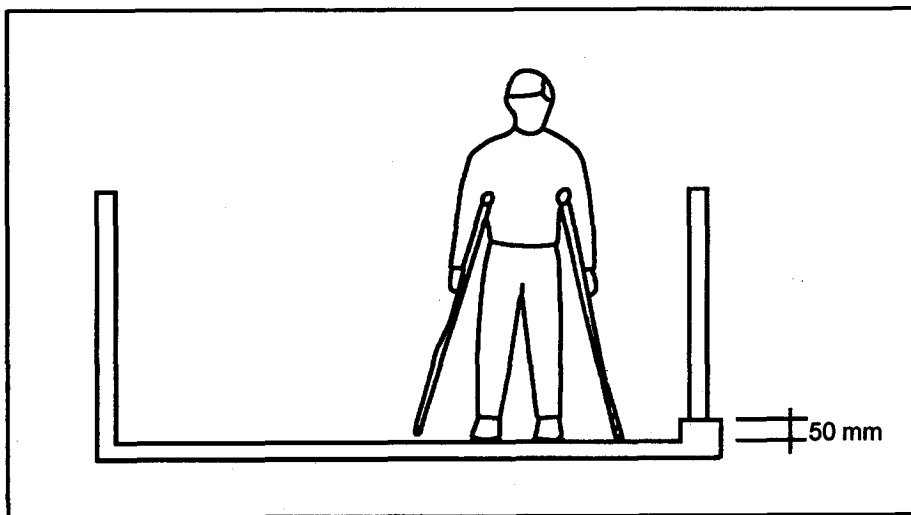

Fig. 12 Shape of passage

To prevent a cane or crutch tip from slipping off the side of the stairs or ramp, install a 20 mm high lip on the exposed edge.

C. SIGHT DISABILITIES

Persons with impaired vision

Persons in this category are totally blind or with impaired vision. Visually impaired persons make use of other senses such as hearing or touch to compensate for the lack of vision. It is necessary to give instructions accessible through the sense of touch (hands, fingers or legs).

While walking with a white cane to spot their feet near the tip of the cane the persons may bump his or her head or shoulder against protruding objects.

Persons with limited vision may be able to discriminate between dark and bright shades and difference in primary colors.



Design requirements

- * Use of guiding blocks for persons with impaired vision to guide them within the buildings and facilities and out side the building. (Refer details of guiding/warning blocks).
- * Installation of information board in braille.
- * Installation of audible signages (announcements)
- * Removal of any protruding objects and sufficient walking space for safe walking.
- * For persons with limited vision use of contrasting color arrangements.

D. HEARING DISABILITIES

Persons with impaired hearing

Persons in this category are totally deaf or have difficulty in hearing. They are generally use their sight to gather information in public places.

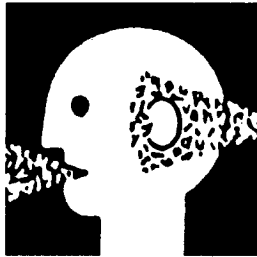

Design requirements

- * Provision of information board in an easily understandable manner.
- * Provision of illuminated signages, layout diagrams to help the persons easily reach the desired place.

ELDERLY PERSONS

Elderly persons may suffer impaired mobility, sight disabilities (partially or fully), hearing disabilities or any other physical difficulties, for which the design guidelines for them within and outside the buildings and facilities shall be similar like other physically disabled persons.

Classification of Buildings

Category 1	Residential
Category 2	Commercial
Category 3	Manufacturing
Category 4	Public and Semipublic
Category 5	Recreational
Category 6	Transportation & Communication
Category 7	Agriculture & Water Bodies
Category 8	Special Area

CATEGORY 1	RESIDENTIAL Primary Residential Zone Mixed Residential Zone Unplanned Informal Residential Zone
CATEGORY 2	COMMERCIAL Retail Shopping Zone General Business & Commercial District Centres Wholesale, Godowns, Warehousing/Regulated Markets.
CATEGORY 3	MANUFACTURING Service and Light Industry Extensive and Heavy Industry Special Industrial Zone, Hazardous, Noxious, and chemical.
CATEGORY 4	PUBLIC AND SEMI-PUBLIC Govt/Semi Govt/Public Offices Education and Research, Medical and Health Social Cultural and Religious Utilities and Services Cremation and Burial Grounds

CATEGORY 5

RECREATIONAL

Playground/stadium/sports complex
Parks & Gardens-Public open spaces
Special recreational zone-restricted openspaces
Multi open-space (Maidan)

CATEGORY 6

TRANSPORTATION & COMMUNICATION

Roads
Railways
Airports
Seaports and Dockyards
Bus Depots/Truck Terminals &
Freight complex
Transportation and Communication

CATEGORY 7

AGRICULTURE & WATER BODIES

Agriculture
Forest
Poultry and Dairy Farming
Rural Settlements
Brick Kiln and Extractive Areas
Water Bodies

CATEGORY 8

SPECIAL AREA

Old Built up (core) Area
Heritage and Conservation Area
Scenic Value Areas
Village Settlement
Other uses

Min. Access Provisions Required in Various Types of Buildings

Type of Building

Minimum Provisions

- | | |
|--|---|
| * Single detached, single dwelling units. | A minimum of 2 per cent of the total number of units to be constructed with barrier-free features. (Adoptable Units) |
| * Staff housing, multiple dwelling and high rise residential units and tenements | A minimum of 1 unit for every 25, plus 1 additional unit for every 100 units thereafter. Entrances and exits to be accessible. |
| * Tenement houses, row houses, apartments and town houses. | A minimum of 1 unit for up to 150 units, and a minimum of 1 additional unit for every 100 units thereafter to be accessible. |
| * Post offices, banks and financial service institutions | A minimum of 1 lowered service counter on the premises.

A minimum of 1 lowered automatic teller machine (ATM) / cash disbursement point on the premises. Stamp vending machine. |
| * Shophouses and single-storey shops | Accessible shopping area. |
| * Places of worship | Entrances and exits and main area of worship to be accessible.

Mosques: access to area for ablutions;
Churches: access to confessionals, fonts and chapels;

Temples: access to shrines and courtyards. |

* Food centres

A minimum of 1 table without stools or seats attached to the floor for every 10 tables.

A minimum of 2 tables without stools or seats attached to the floor for the whole premises.

Accessible entrance

* Community centres, village halls, auditoria, concert halls, assembly halls, cinemas, theatres and other places of public assembly.

Accessible entrances, exists, aisles and main community or public gathering areas.

Accessible toilet facilities should be nearby.,

Seating for persons with disabilities to be accessible from main entrances and lobbies.

Various seating/viewing choice to be provided for persons in wheelchairs throughout the main seating area.

A minimum of 2 wheelchair spaces for seating capacity up to 100 seats.

A minimum of 4 wheelchair spaces for seating capacity from over 100 to 400 seats.

Design Elements within the Building Premises (PUBLIC BUILDINGS)

1. Site Planning
 - * Walks and Paths
 - * Levels and Grooves
 - * Kerb Ramp
2. Parking
3. Approach to Plinth Level
 - * Ramped Approach
 - * Stepped Approach
4. Entrance Landing
5. Corridor
6. Entrance/Exit Door
7. Windows
8. Stair Ways
9. Lift
10. Toilet
11. Signages
12. Other Facilities
 - * Counter
 - * Water Fountain
 - * Telephone
 - * Mailbox
 - * Vending Machine

Site Planning

To accommodate the handicapped and elderly people each building and its site should be planned and designed as an integral unit from the very beginning of the design process.

WALKS AND PATHS

- * Walks should be smooth, hard level surface suitable for walking and wheeling. Irregular surfaces as cobble stones, coarsely exposed aggregate concrete, bricks etc. often cause bumpy rides.
- * The minimum walk way width would be 1200 mm and for moderate two way traffic it should be 1650 .mm - 1800 mm.
- * Longitudinal walk gradient should be 3 to 5% (30 mm - 50 mm in 1 meter)
- * When walks exceed 60 Meter in length it is desirable to provide rest area adjacent to the walk at convenient intervals with space for bench seats. For comfort the seat should be between 350 mm - 425 mm high but not over 450 mm.
- * Texture change in walk ways adjacent to seating will be desirable for blind persons.
- * Avoid grates and manholes in walks. If grates cannot be avoided then bearing bar should be perpendicular to the travel path and no opening between bearing bars greater than 12 mm in width.

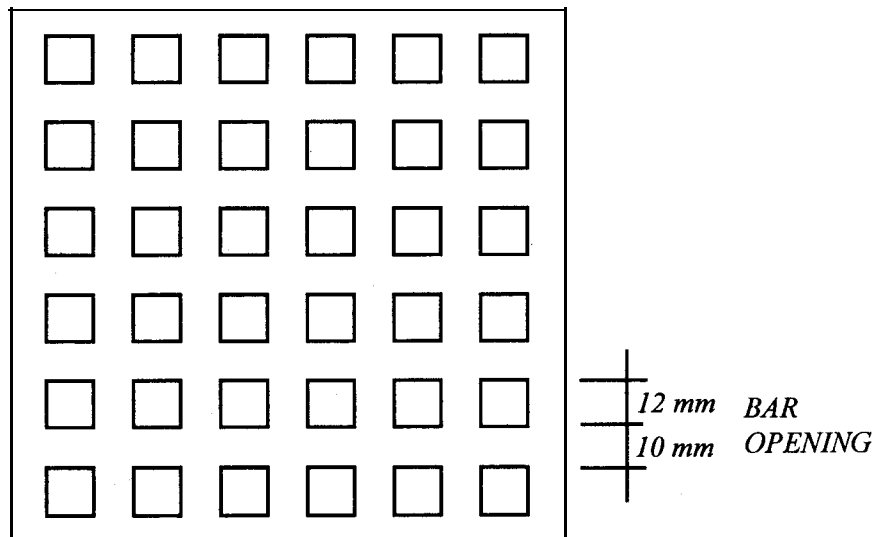
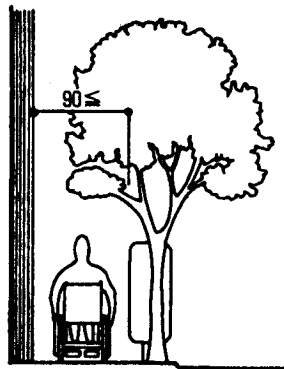
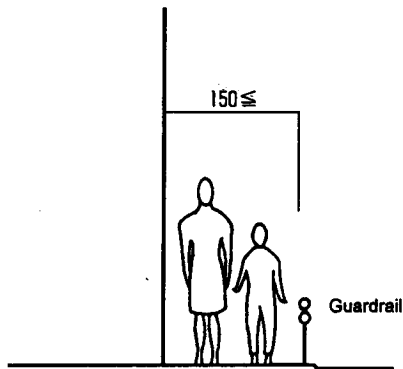

Fig. 13 Details of Grating



LEVELS AND GROOVES

Sidewalk width

(Passing over different levels and grooves)

- * The casters on a wheelchair are about 180 mm in diameter. Therefore, a wheelchair can only get over a small level difference.
- * Use a method that can reduce the height of the level difference, in addition to the methods shown here.



Difference in level

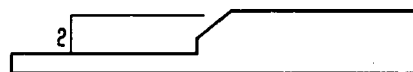

Shape of level difference

- * It can be difficult to move a wheelchair if a caster is caught in a groove.
 - a. It is desirable that there is no difference in level. (If a difference is unavoidable, limit it to 20 mm or less.)
 - b. Round off or bevel the edge.
 - c. To prevent a wheelchair from getting its casters caught in a drainage ditch or other cover.
 - a. Install grating with narrow slots in the direction of movement.
 - b. Treat the grating with a non-slip finish.
 - c. Reduce the gap between an elevator floor and the landing.

KERB RAMP

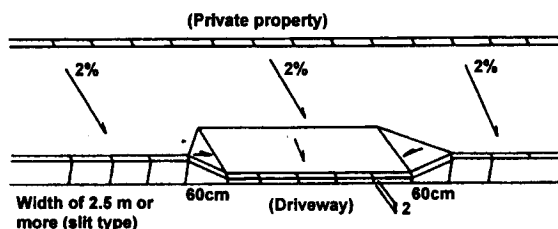

Typical Detail of Walkway

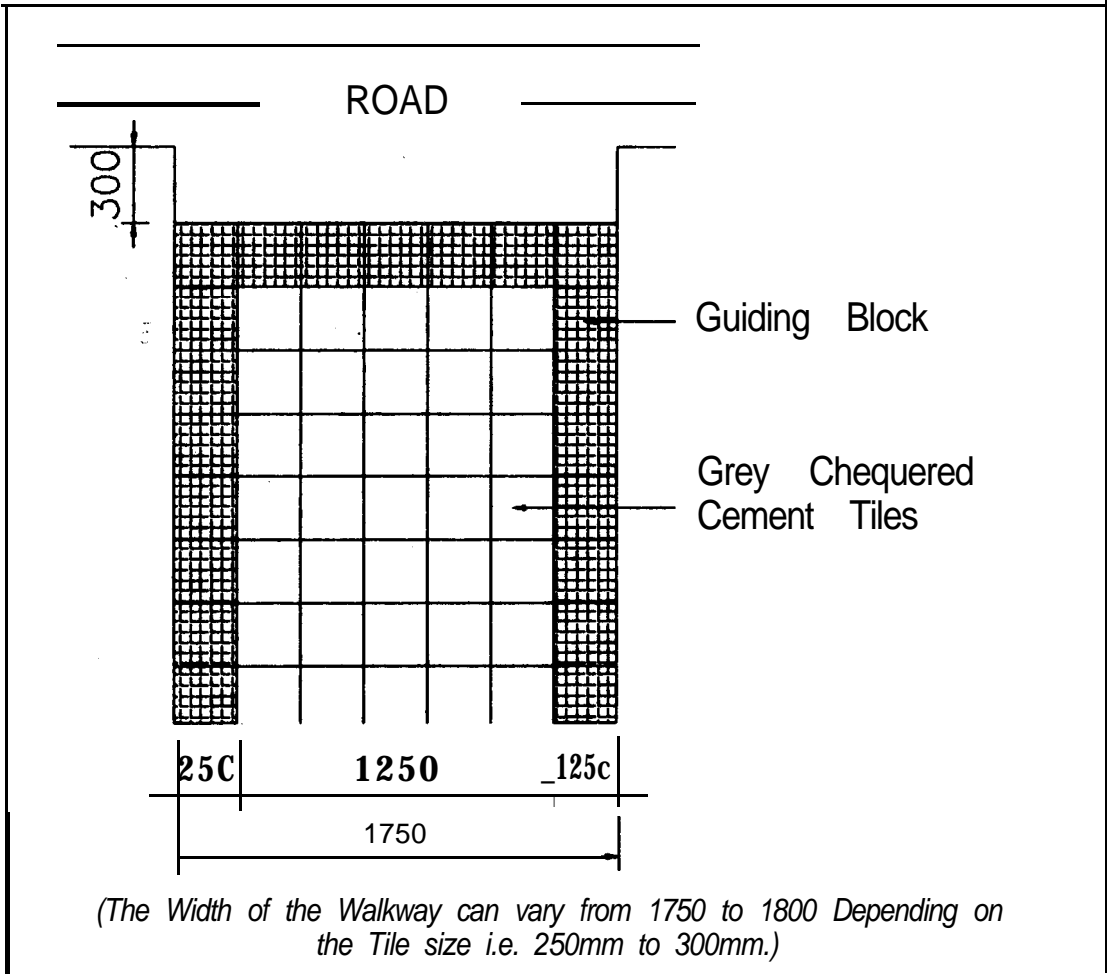

Note :

- * Walkway should be constructed with a non-slip material & different from rest of the area.
- * The walkway should not cross vehicular traffic.
- * The manhole, tree or any other obstructions in the walkway should be avoided.
- * Guiding block at the starting of walkway & finishing of the walkway should be provided.
- * Guiding block-can be of red chequered tile, smooth rubble finish, prima regina, Naveen tiles or any other material with a different texture as compared to the rest of the area.

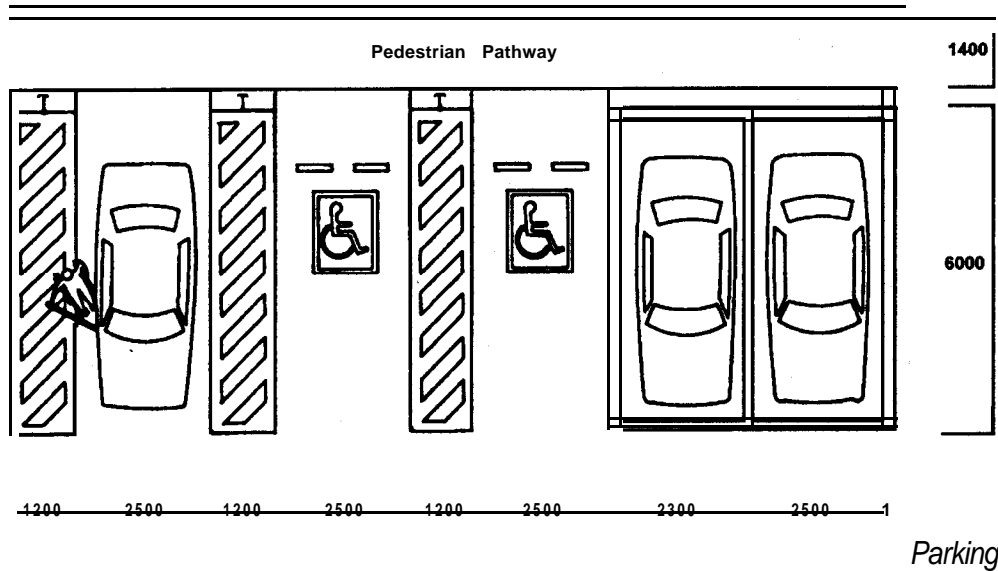

PARKING

Parking :- For parking of vehicles of handicapped people the following provisions shall be made:

- a) Surface parking for two care spaces shall be provided near entrance for the physically handicapped persons with maximum travel distance of 30 M from building entrance.
- b) The width of parking bay shall be minimum 3.60 Meter.
- c) The information stating that the space is reserved for wheel chair users shall be conspicuously displayed.
- d) Guiding floor materials shall be provided or a device which guides visually impaired persons with audible signals or other devices which serves the same purpose shall be provided.

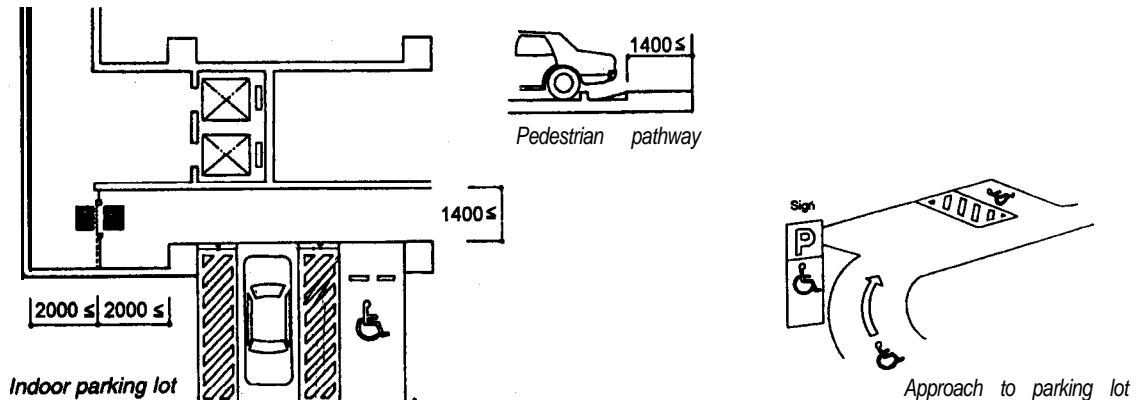

Approach to Plinth Level

Approach to plinth level : Every building should have at least one entrance accessible to the handicapped and shall be indicated by proper signage. This entrance shall be approached through a ramp together with the stepped entry.

Ramped Approach : Ramp shall be finished with non slip material to enter the building. Minimum width of ramp shall be 1800 mm. with maximum gradient 1:12, length of ramp shall not exceed 9.0 M having double handrail at a height of 800 and 900 mm on both sides extending 300 mm. beyond top and bottom of the ramp. Minimum gap from the adjacent wall to the hand rail shall be 50 mm.

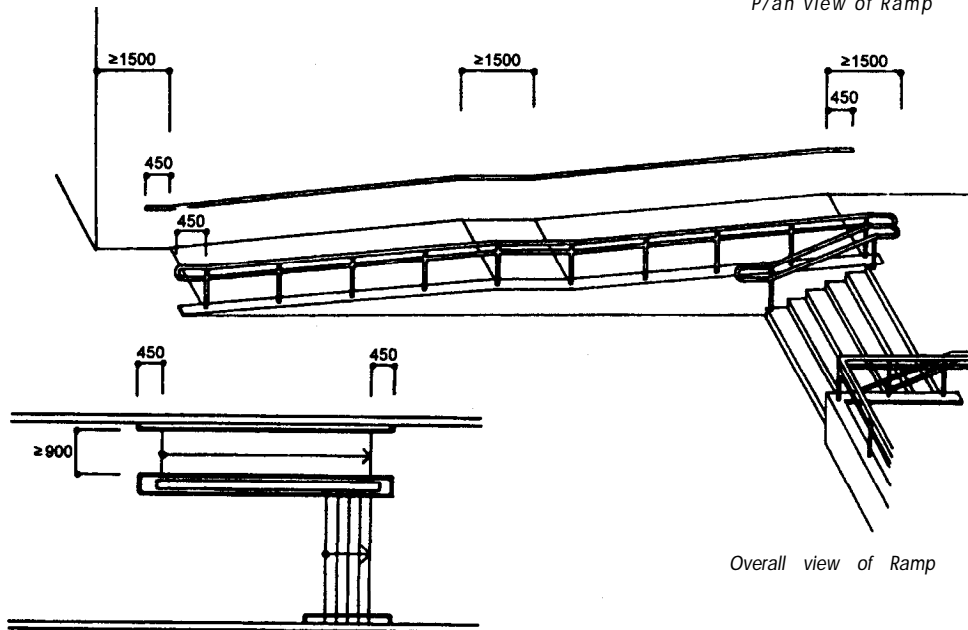
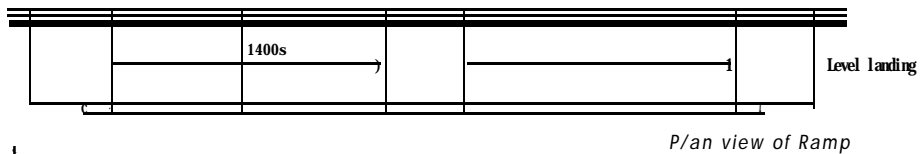
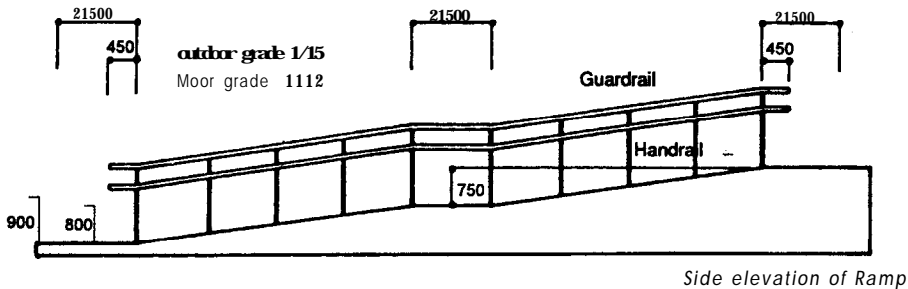

Ramp combined with staircase

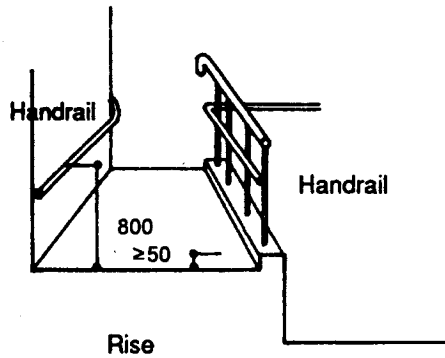

CROSS SECTION OF RAMP

- * When climbing a ramp in a wheelchair, the upper limbs must bear the burden of propelling the body up the ramp.
- * When descending a ramp in a wheelchair, especially on steep ramps, there is a possibility of the wheelchair running out of control because the user must manually control the speed.
- * Prevent the installation of steep ramps.
 - (a) Make sure the grade of a ramp is a moderate rise of 10 mm to each 120 mm of travel.
 - (b) Provide a flat surface 1500 mm or more in length at the top and bottom of the ramp for a wheelchair to pause and prevent it from going out of control.

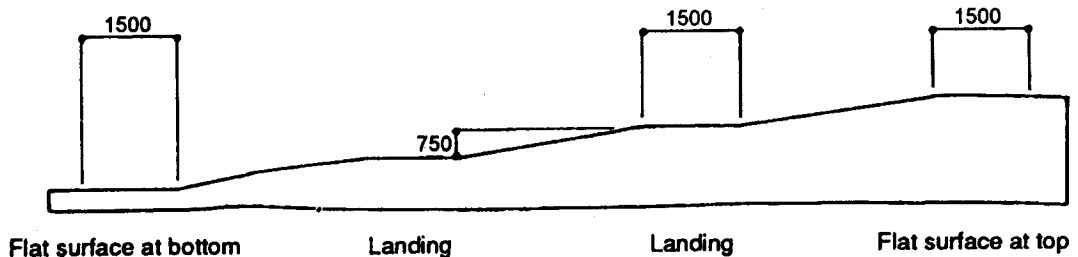

Cross Section of ramp

Stepped Approach :- For stepped approach size of tread shall not be less than 300 mm. and maximum riser shall be 150 mm. Provision of 900 mm high hand rail on both sides of the stepped approach similar to the ramped approach.

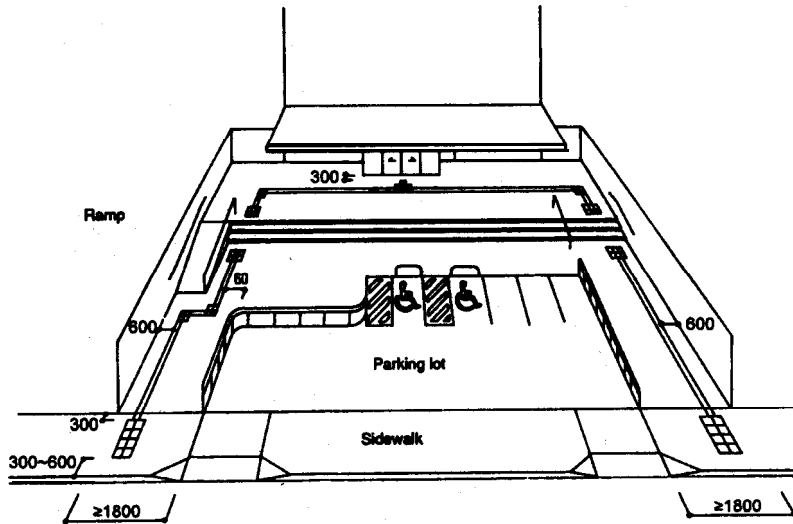

Overall view of approach

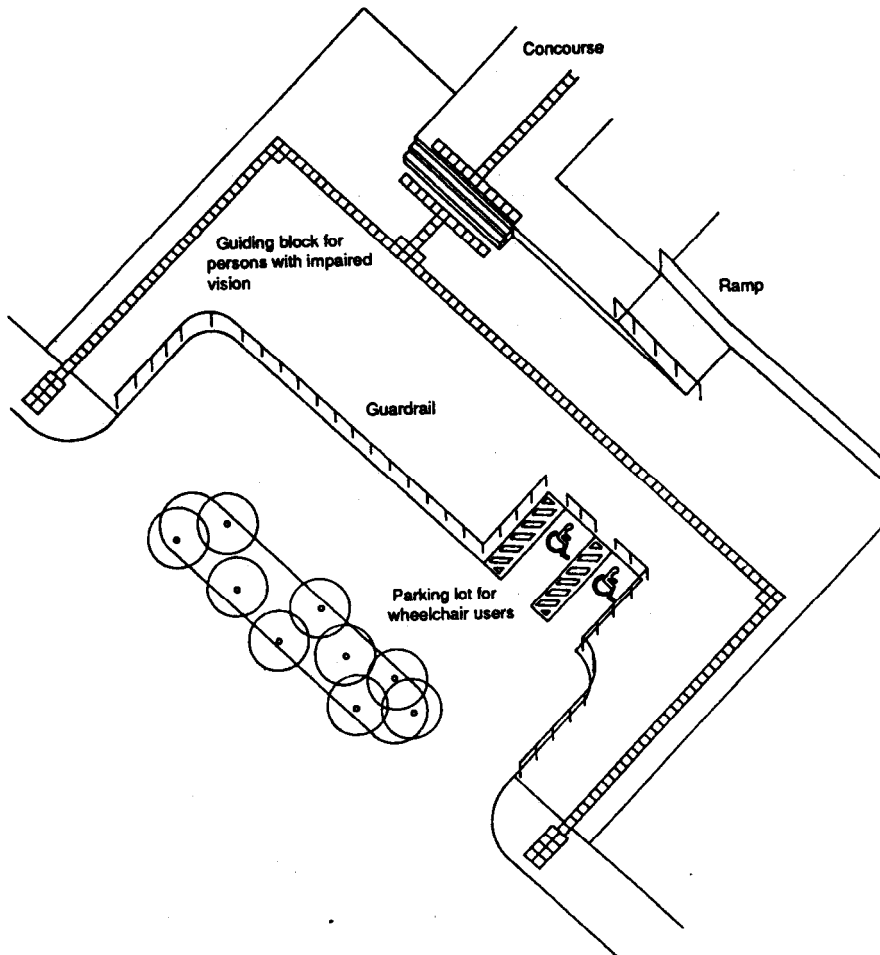

Ramp Details

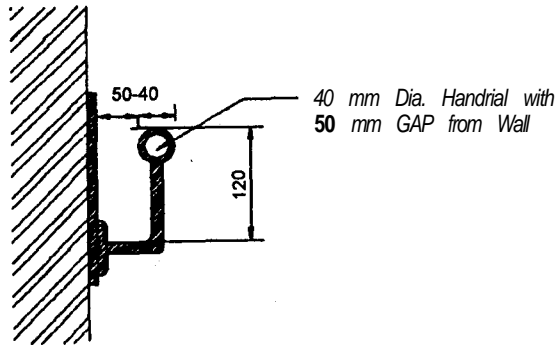

Fixing Detail of Handrail to the Wall

Guiding block 300 mm
away from starting
& ending of ramp

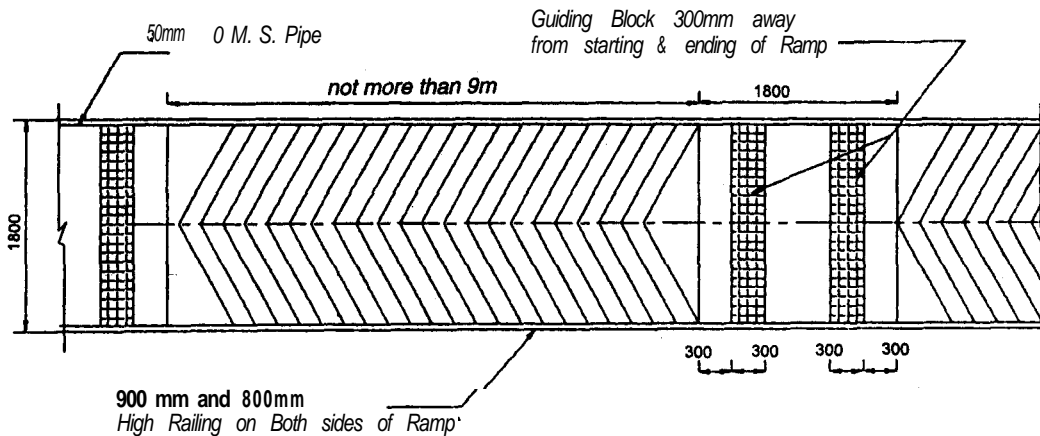
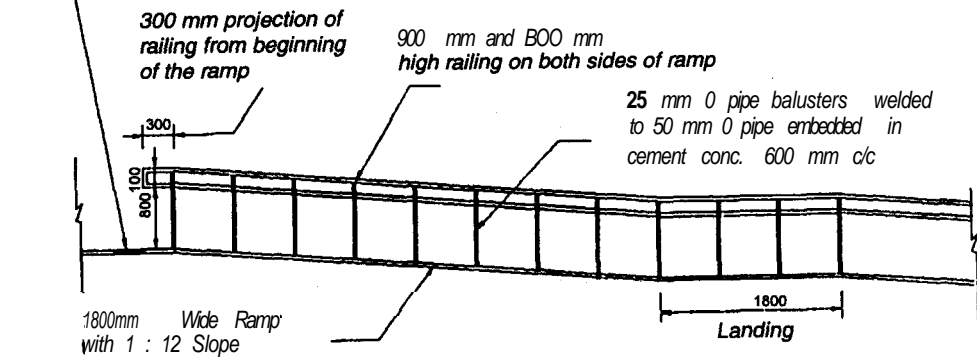

PLAN

Entrance Landing

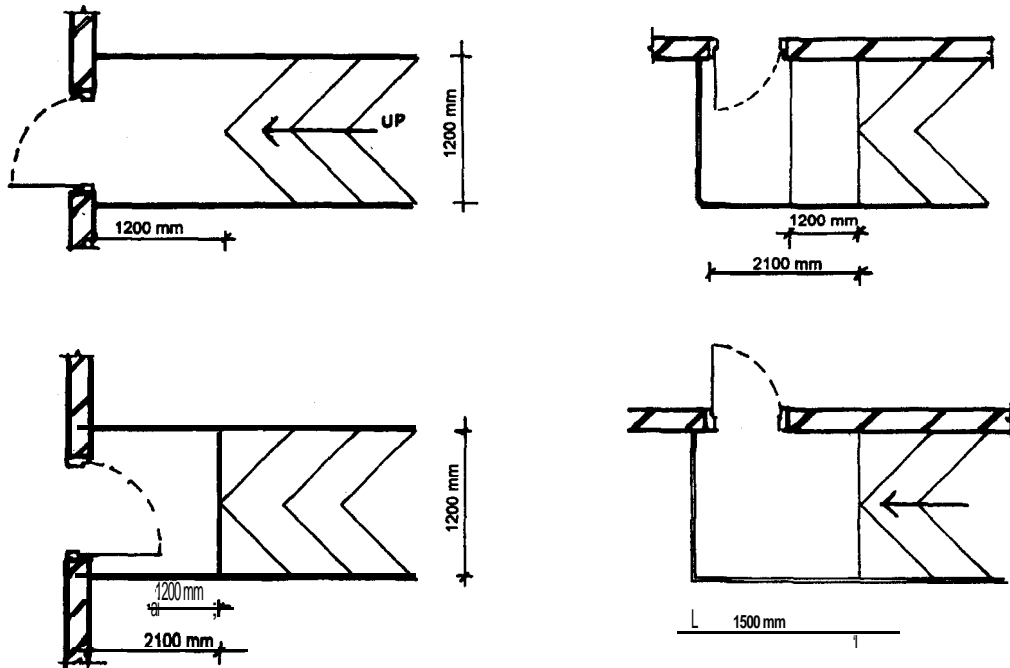

Entrance Landing :- Entrance landing shall be provided adjacent to ramp with the minimum dimension 1800 x 2000 mm. The entrance landing that adjoin the top end of a slope shall be provided with floor materials to attract the attention of visually impaired persons (limited to coloured floor material whose color and brightness is conspicuously different from that of the surrounding floor material or the material that emit different sound to guide visually impaired persons hereinafter referred to as “guiding floor material” (Annexure - I). Finishes shall have a non slip surface with a texture traversable by a wheel chair. Curbs wherever provided should blend to a common level.

Corridor

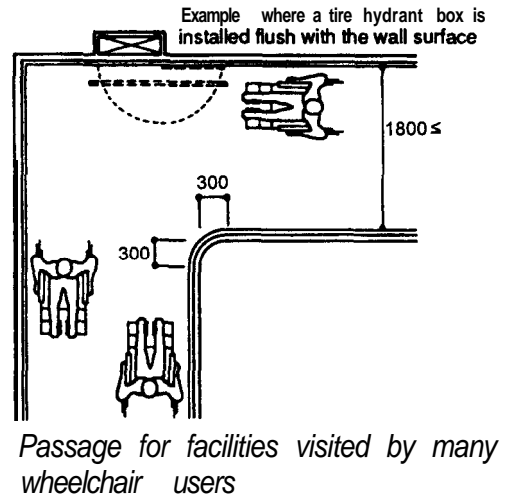
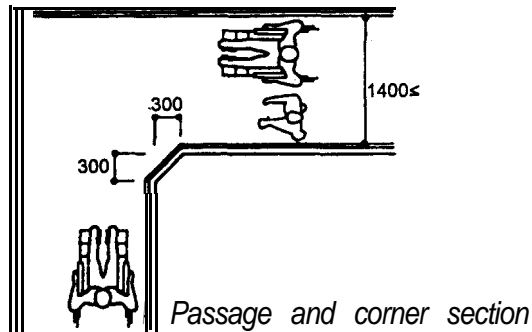

Corridor connecting the entrance/exit for the handicapped:- The corridor connecting the entrance/exit for handicapped leading directly outdoors to a place where information concerning the overall use of the specified building can be provided to visually impaired persons either by a person or by signs, shall be provided as follows:

- 'Guiding floor materials' shall be provided or devices that emit sound to guide visually impaired persons.
- The minimum width shall be 1500 mm.
- In case there is a difference of level slope ways shall be provided with a slope of 1:12.
- Hand rails shall be provided for ramps/slope ways.

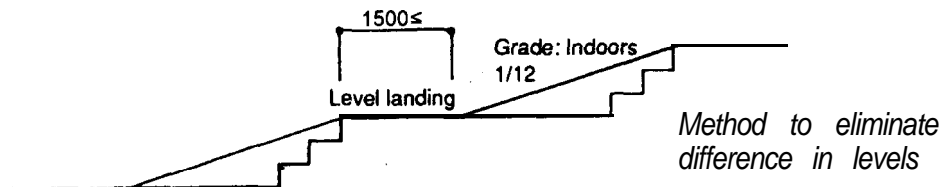

1. REQUIRED WIDTH FOR PASSAGE OF WHEELCHAIR

- (1) The wheelchair body itself is about 650 mm wide. Allowing for the use of hands and arms outside the wheelchair, the passage must be as wide as 900 mm or more.
- (2) Locations such as entrances and exists can be 900 mm wide. However, a continuous passage (e.g. a corridor) must at least be 900 mm wide to allow for slight side-to-side movement of the wheelchair as it travels.

Required width for Passage of Wheelchair

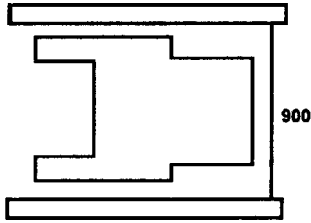

For residence only

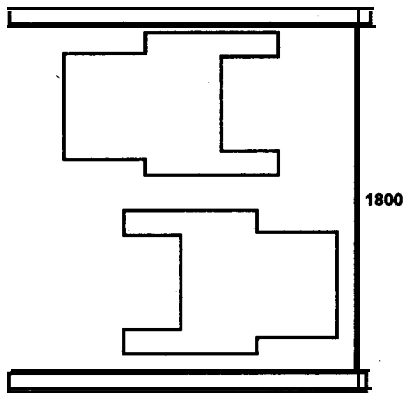
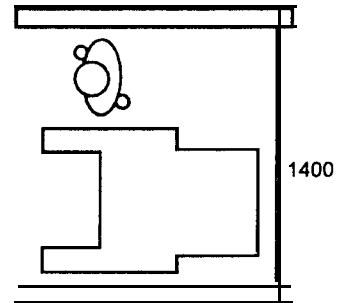
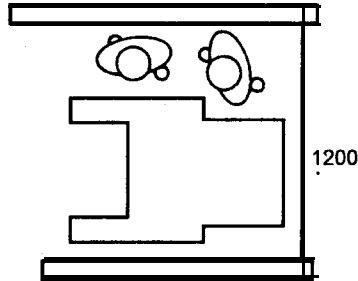

Corridor, ramp

- a. Corridors etc. must at least be 900 mm wide. At this width, however, it is difficult to turn a wheelchair.

2. REQUIRED WIDTH TO TURN A WHEELCHAIR

The diagram on the right shows the space required to turn a wheelchair.

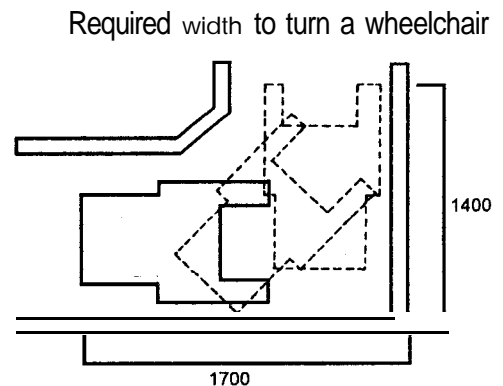

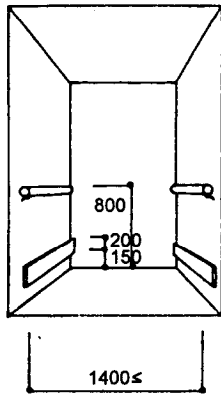

Cross section of corridor

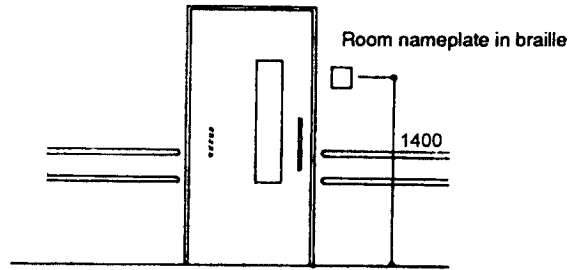

Room entrance/exit and surroundings

Room nameplate in braille

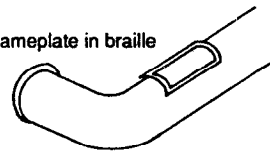

Hand rail

Protruding objects, such as directional signs, tree branches, wires, guy ropes, public telephone booths, benches and ornamental fixtures should be installed with consideration of the range of a visually impaired person's cane.

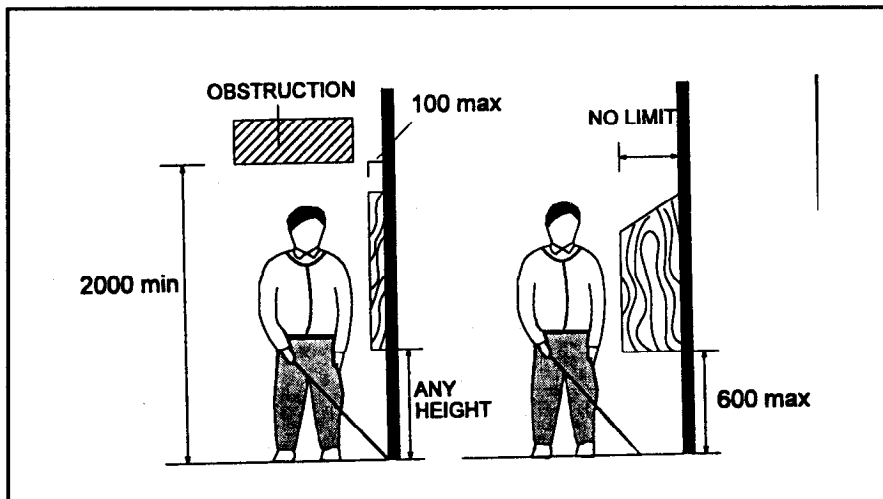

Protruding objects

Entrance/Exit Door

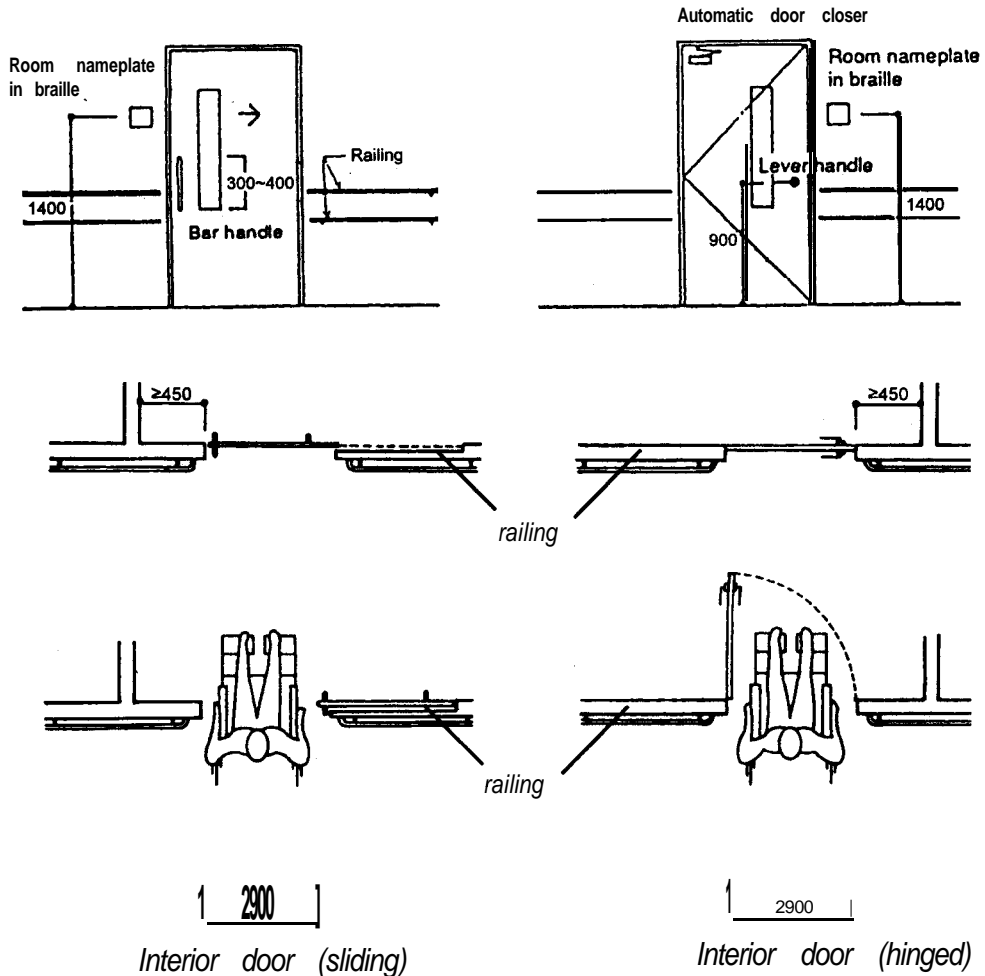

Exit/Entrance Door Minimum clear opening of the entrance door shall be 900 mm. and it shall not be provided with a step that obstructs the passage of a wheel chair user. Threshold shall not be raised more than 12 mm.

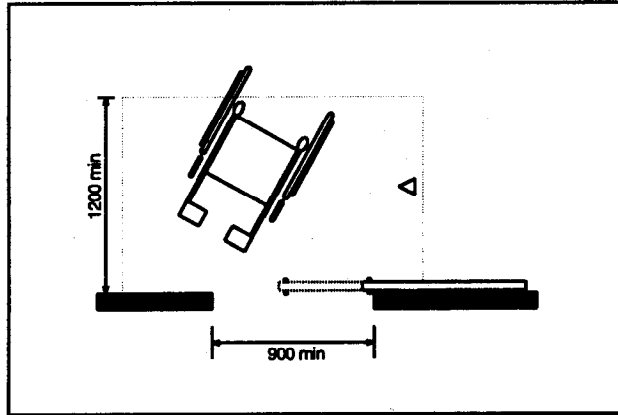

Sliding door

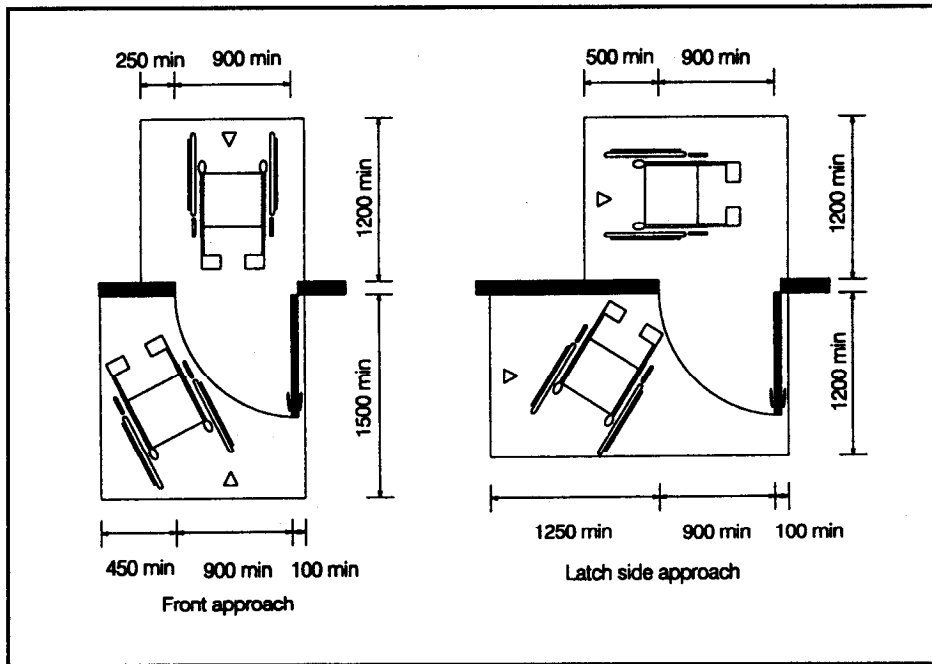

Doorways

Windows

- * A window should have handies/controls at a height that permits use from wheelchairs.
- * A window should have an unobstructed viewing zone for wheelchair users.
- * Curtain or Venetian blind controls/ropes should be accessible for wheelchair users.

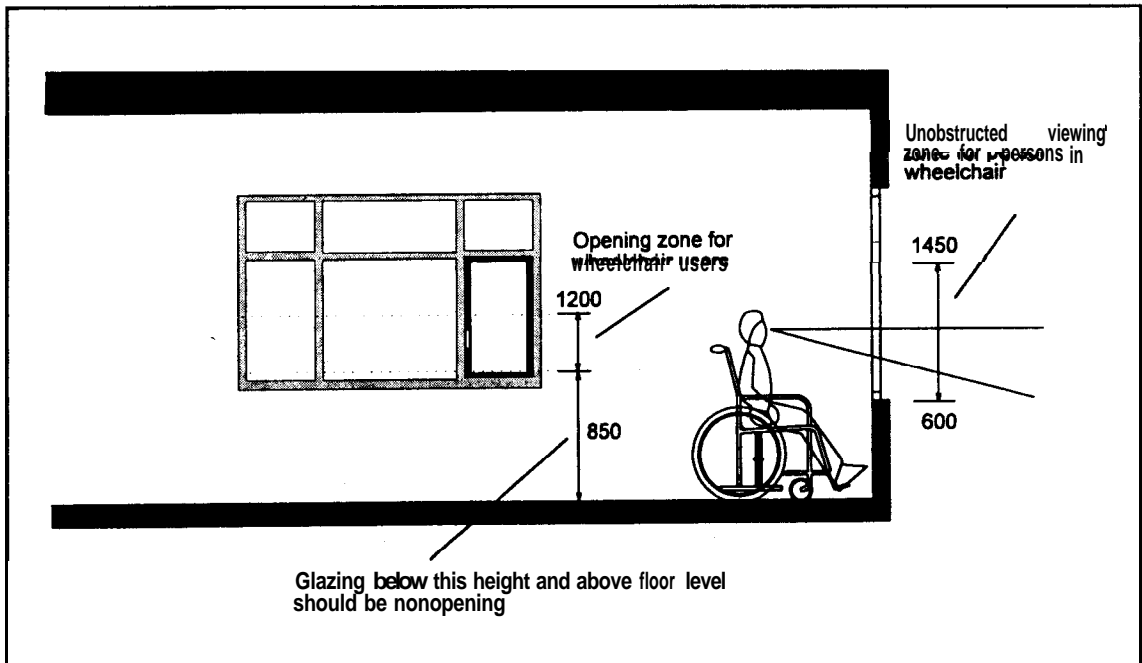

Windows

Steps and Stairs

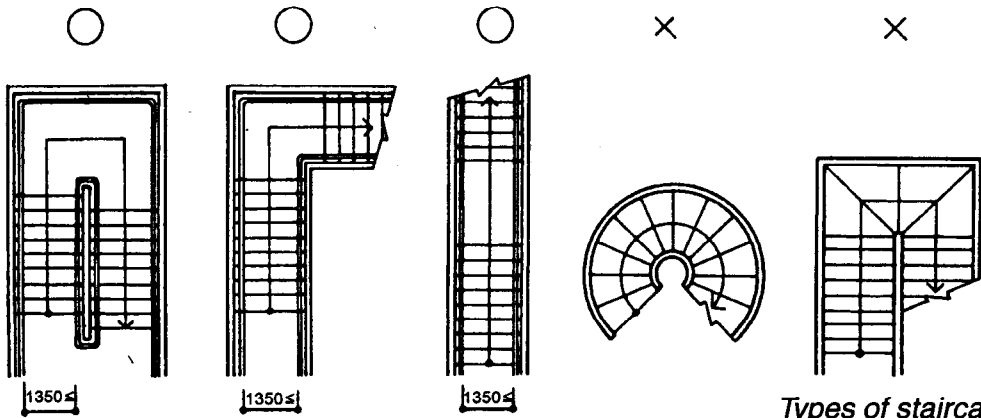

Types of staircases

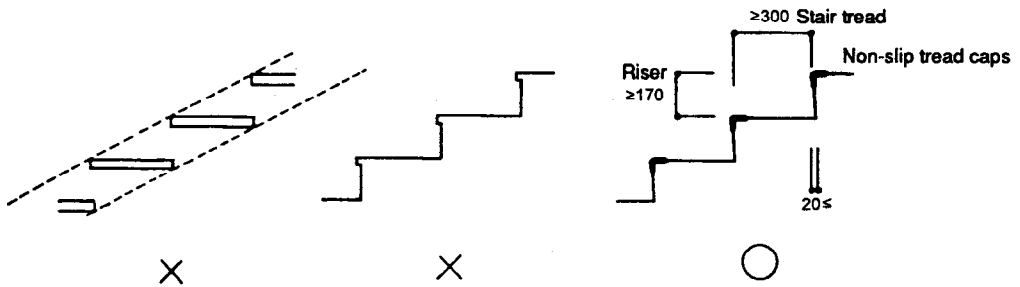

Stair dimensions

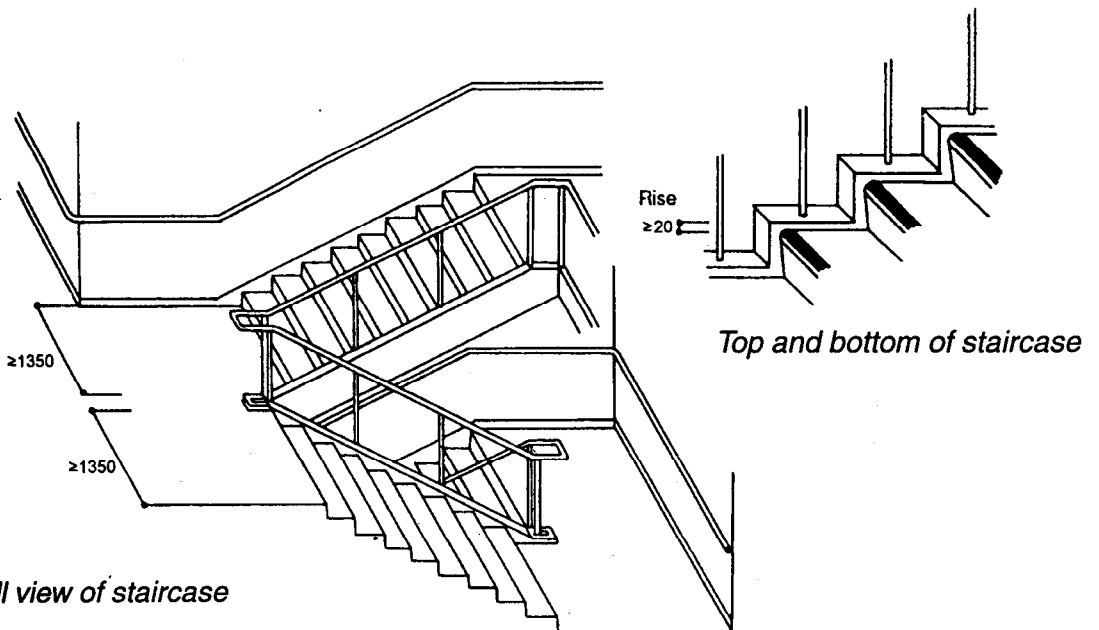

Overall view of staircase

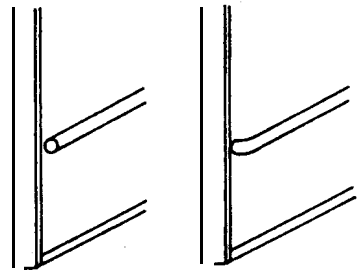
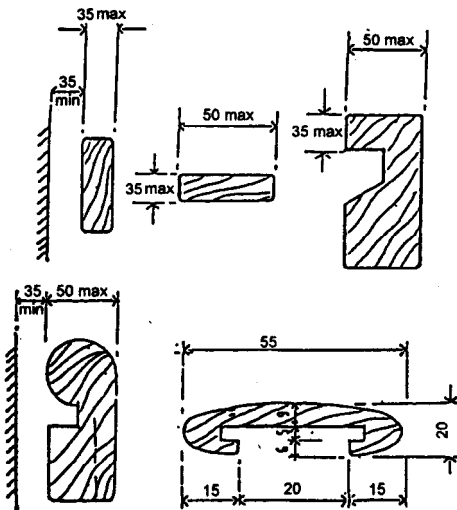
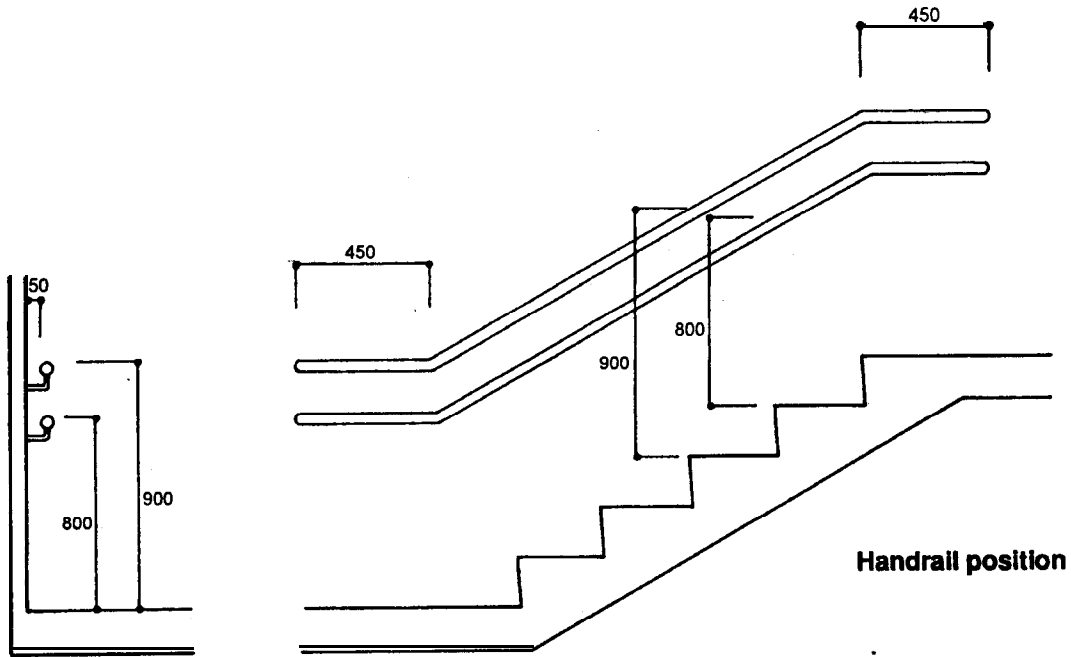

X

O

Edge of handrail

Room nameplate in braille

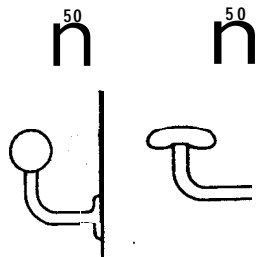
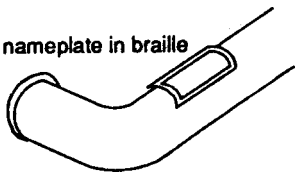

Handrail shape and clearance from wall surface

Lift

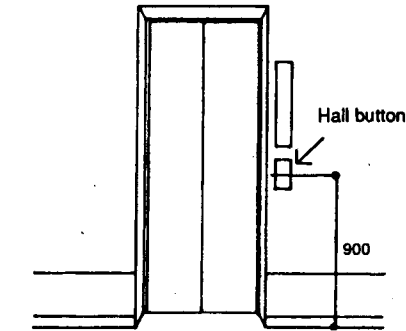

Elevator entrance

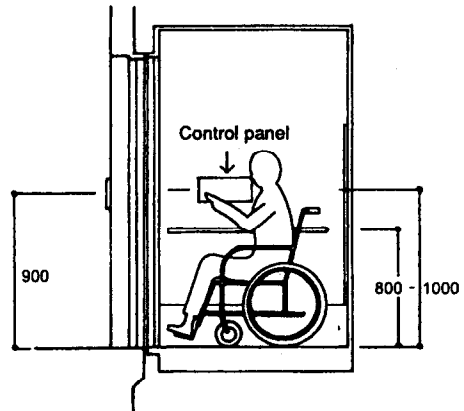

Height of control panel and standard dimensions

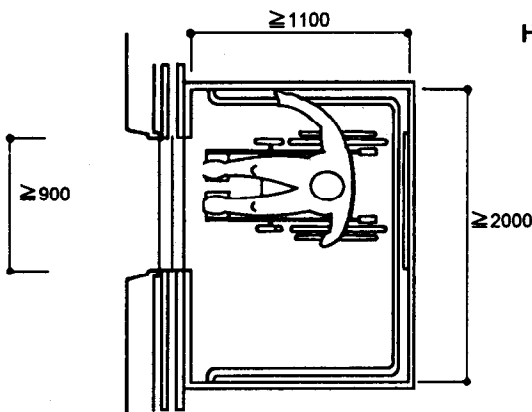

Space Inside elevator

Lifts :- Wherever lift is required as per bye-laws, provision of at least one lift shall be made for the wheel chair user with the following cage dimensions of lift recommended for passenger lift of 13 persons capacity by Bureau of Indian Standards.

Clear internal depth : 1100 mm.

Clear internal width : 2000 mm.

Entrance door width : 900 mm.

- A hand rail not less than 600 mm. long at 800-1000 mm. above floor level shall be fixed adjacent to the control panel.
- The lift lobby shall be of an inside measurement of 1800 x 1800 mm. or more.
- The time of an automatically closing door should be minimum 5 seconds and the closing speed should not exceed 0.25 M/ Sec.
- The interior of the cage shall be provided with a device that audibly indicates the floor the cage has reached and indicates that the door of the cage for entrance/exit is either open or closed.

Toilet

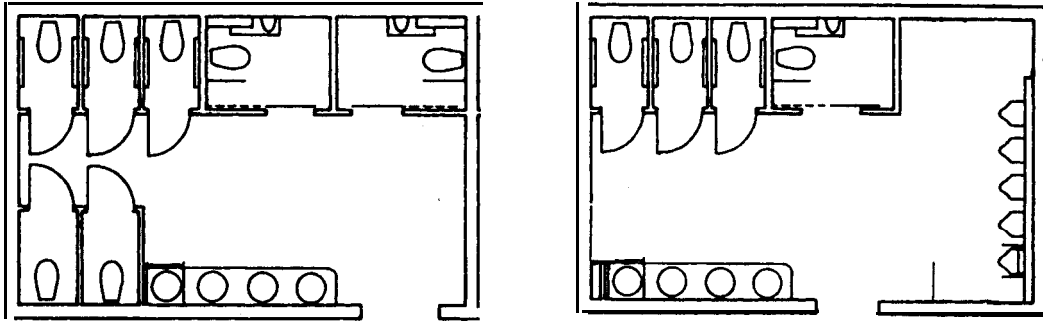

One special W.C. in a set of toilet shall be provided for the use of handicapped with essential provision of wash basin near the entrance for the handicapped.

- * The minimum size shall be 1500 x 1750 mm.
- * Minimum clear opening of the door shall be 900 mm. and the door shall swing out.
- * Suitable arrangement of vertical/horizontal handrails with 50 mm. clearance from wall shall be made in the toilet.
- * The W.C. seat shall be 500 mm. from the floor.

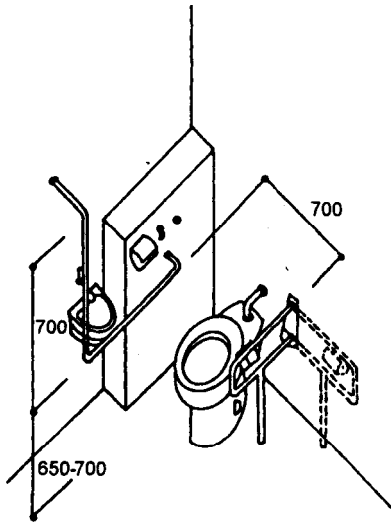

Handrail (Inside stall)

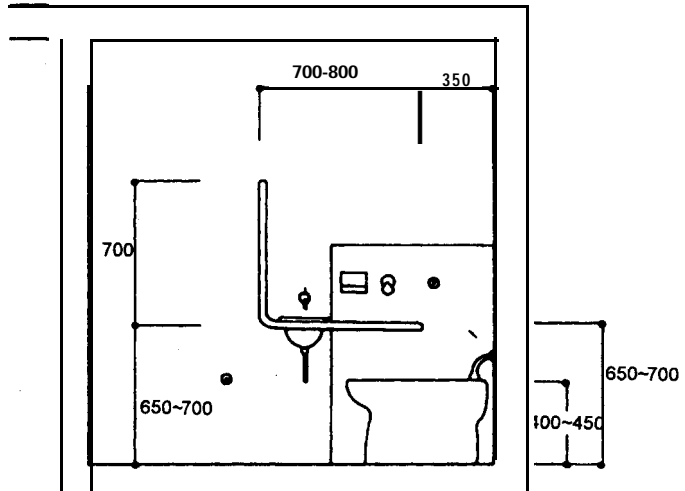

Side elevation of toilet stall

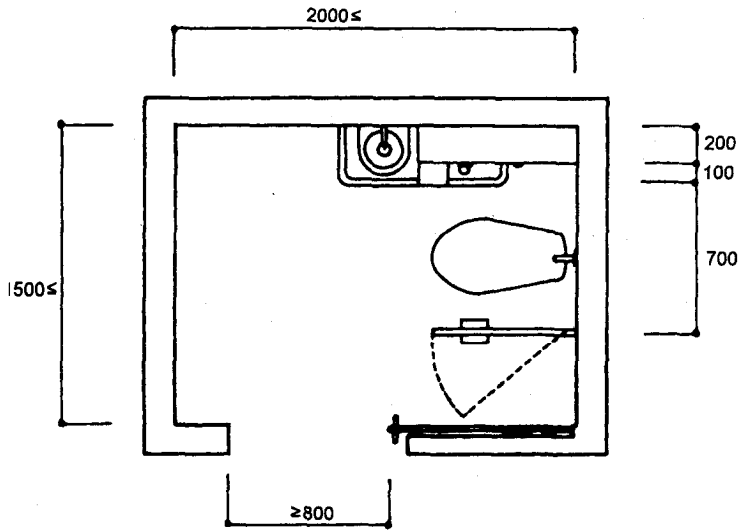

Plan view of toilet stall

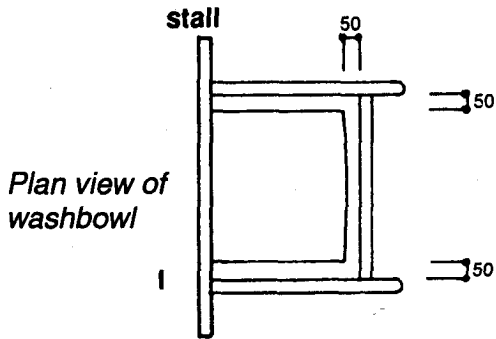

Side elevation of washbowl

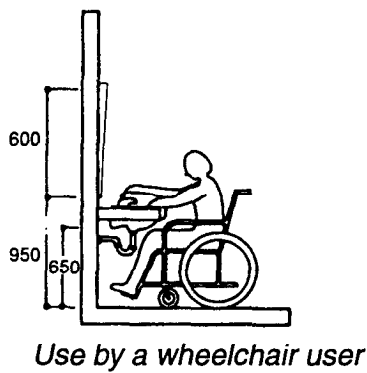
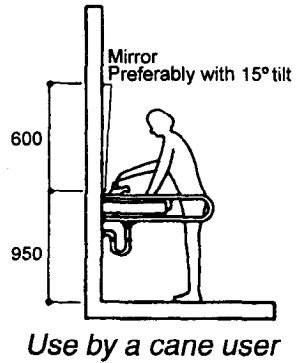
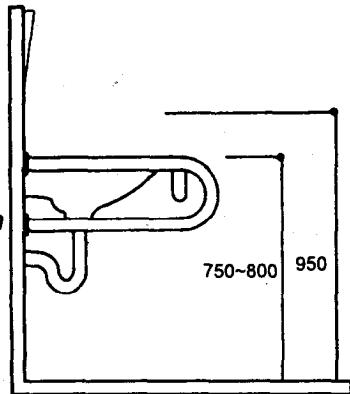

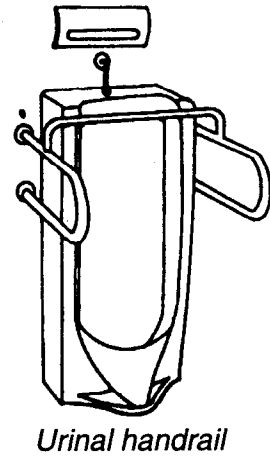
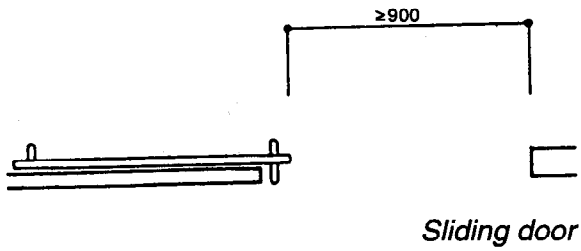
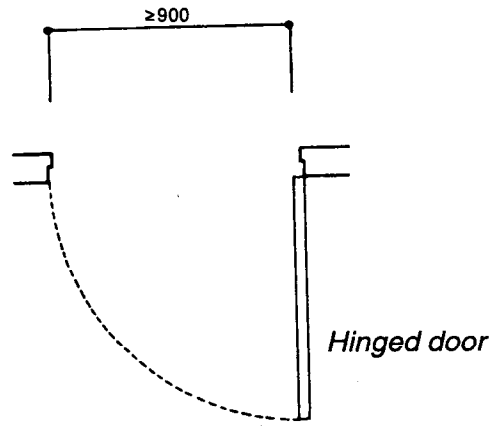

Typical Toilet

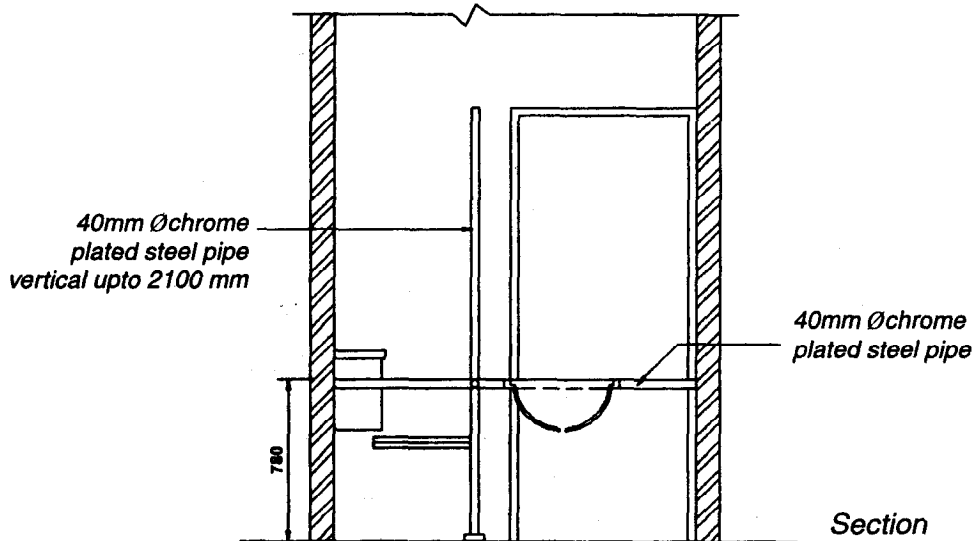
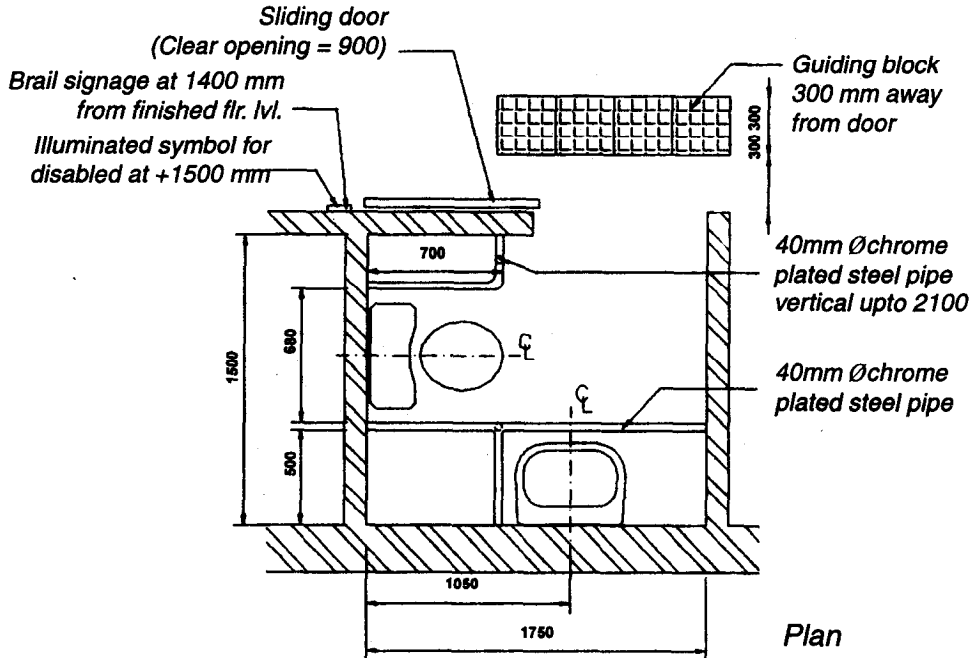

- * Toilet floor shall have a non-slip surface without any lvl. difference.
- * Guiding block near the entry should have a textural difference, (e.g. Diamon Tiles, Prima Regina Tiles, Undressed Granite)
- * Light-weight PVC door shutter should be provided as a sliding door
- * Provision of vertical & horizontal rail as 40 mm C.P. Steel Pipe.

Signages

The main purpose of signs should be to provide a clear designation of places, warnings and routing information. A person in a wheel chair is less than 1200 mm high. A person who is partially sighted needs contrasting texture along side walkways and audible signs for dangerous areas,. Signs should **be** useful to everyone, easily seen from eye level, readable by moving the fingers and well lighted for night time identification.

- * Signs shall indicate the direction and name of the accessible facility and incorporate the symbol of access.

- * The size, type and layout of lettering on signs shall be clear and legible.

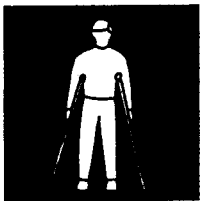

'HEIGHT' OF LETTER FOR VARYING VIEWING DISTANCE

Required viewing distance (M)	Minimum height of letters (MM)
2	6
3	12
6	20
8	25
12	40
15	50
25	80
35	100
40	130
50	150

HEIGHT OF SYMBOL OF ACCESS FOR VARYING VIEWING DISTANCE

Required viewing distance (M)	Minimum size of symbol (MM)
0.7	60x60
7.18	110x110
	Min. 200 x 200
	Max. 450 x 450

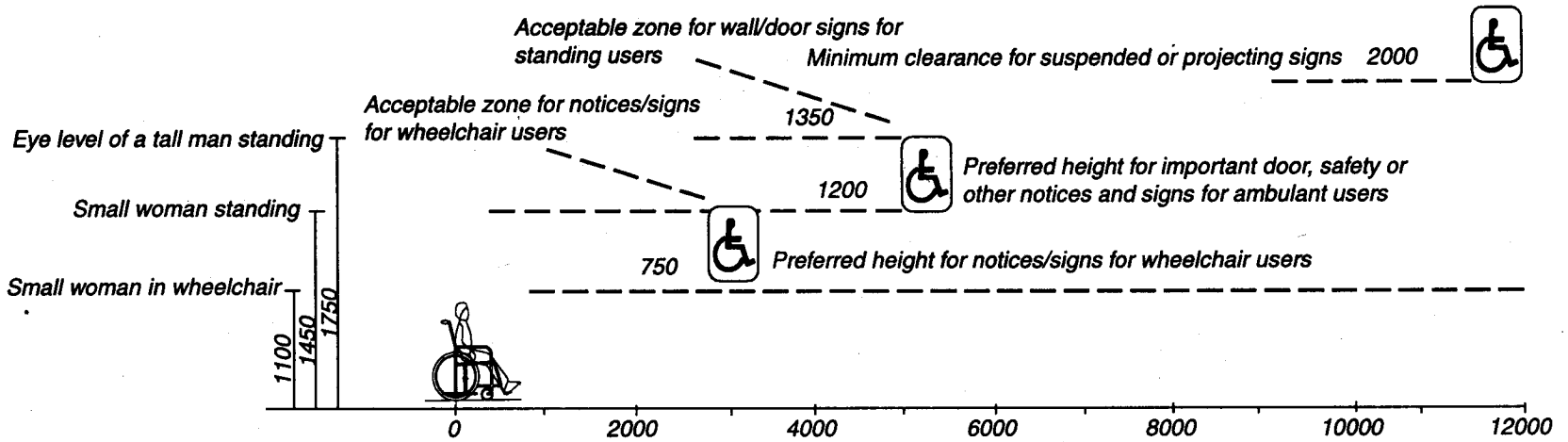

- * Signs should be in contrasting colours and preferably be embossed in distinct relief to allow visually impaired persons to obtain the information they contain by touching them.
- * Simple symbols and contrasting colours which are universally recognized should be used, e.g. green for safety or go, yellow or amber for risk or caution, and red for danger.

Guiding/Warning Floor Material

Shapes of guiding blocks for persons with impaired vision

(1) Shape of liner block

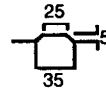
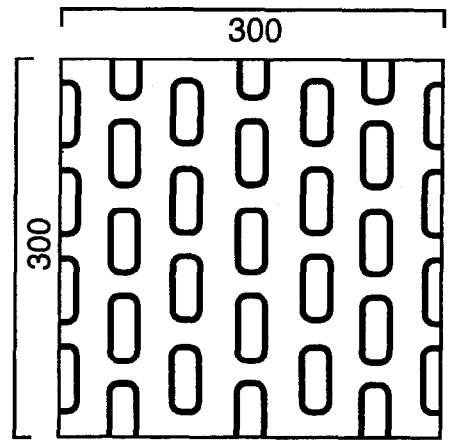
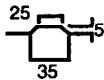
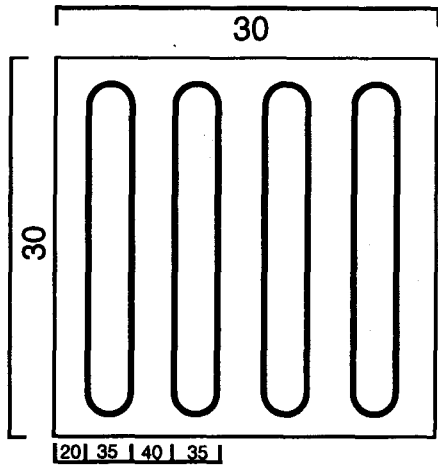

(2) Shape of spot block

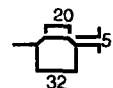
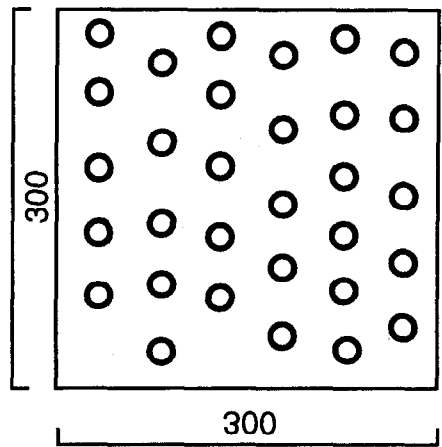
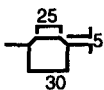
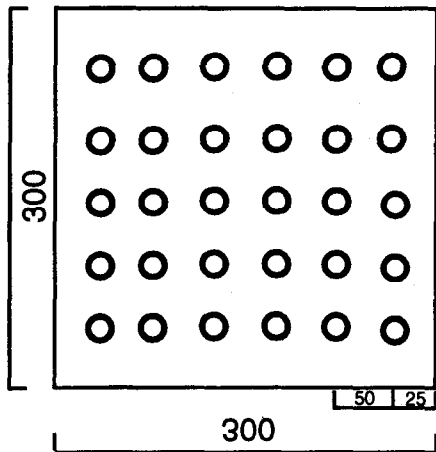

PLACES TO INSTALL GUIDING BLOCKS FOR PERSONS WITH IMPAIRED VISION

1. Immediately in front of a location where there is a vehicular traffic.
2. Immediately in front of an entrance/exit to and from a staircase or multilevel crossing facility.
3. Entrance/exit to and from public transportation terminals, or at boarding areas.
4. Sidewalk section of a guiding or approaching road to the building.
5. Path from a public facility which is frequently visited by persons with impaired vision (e.g. a city hall or library) to the nearest railroad station (to be installed at intervals)
6. Other places where installation of a guiding block for persons with impaired vision is considered effective (e.g. locations abruptly changing in level or ramp).

Exampb using 30 cm square flooring material

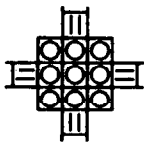

intenection

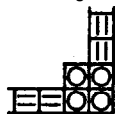

L-shaped intersection

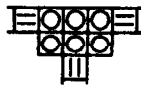

T-shaped intersection

Arrangement of guiding block s for persons with impaired vision

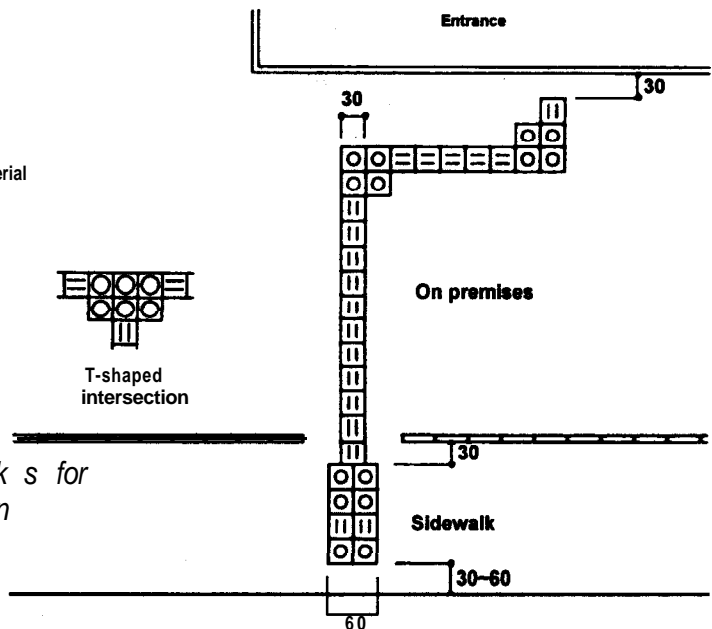

Guiding path and approaching sidewalk to the building

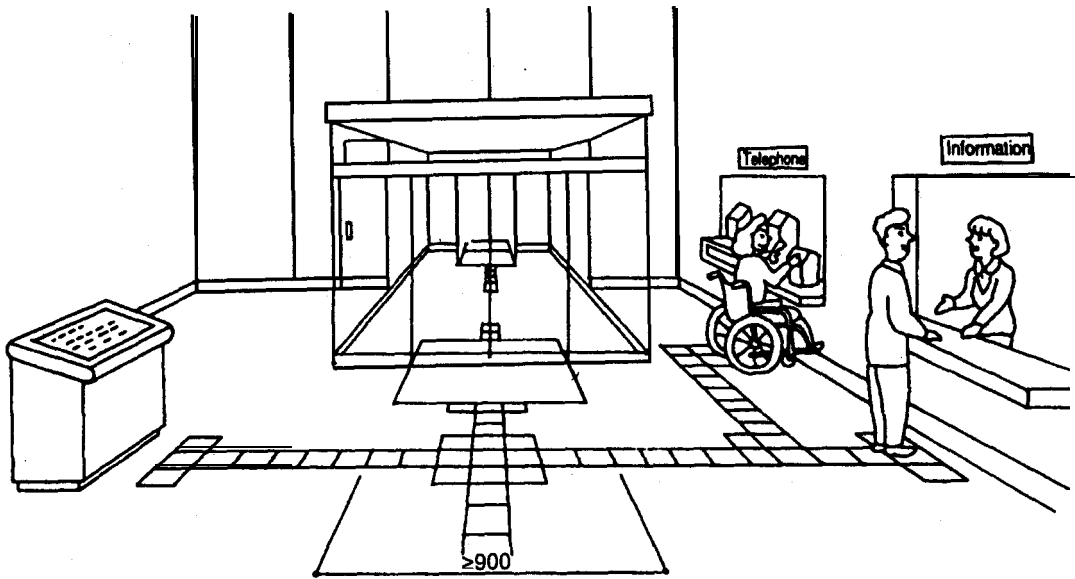

Information, signs at entrance

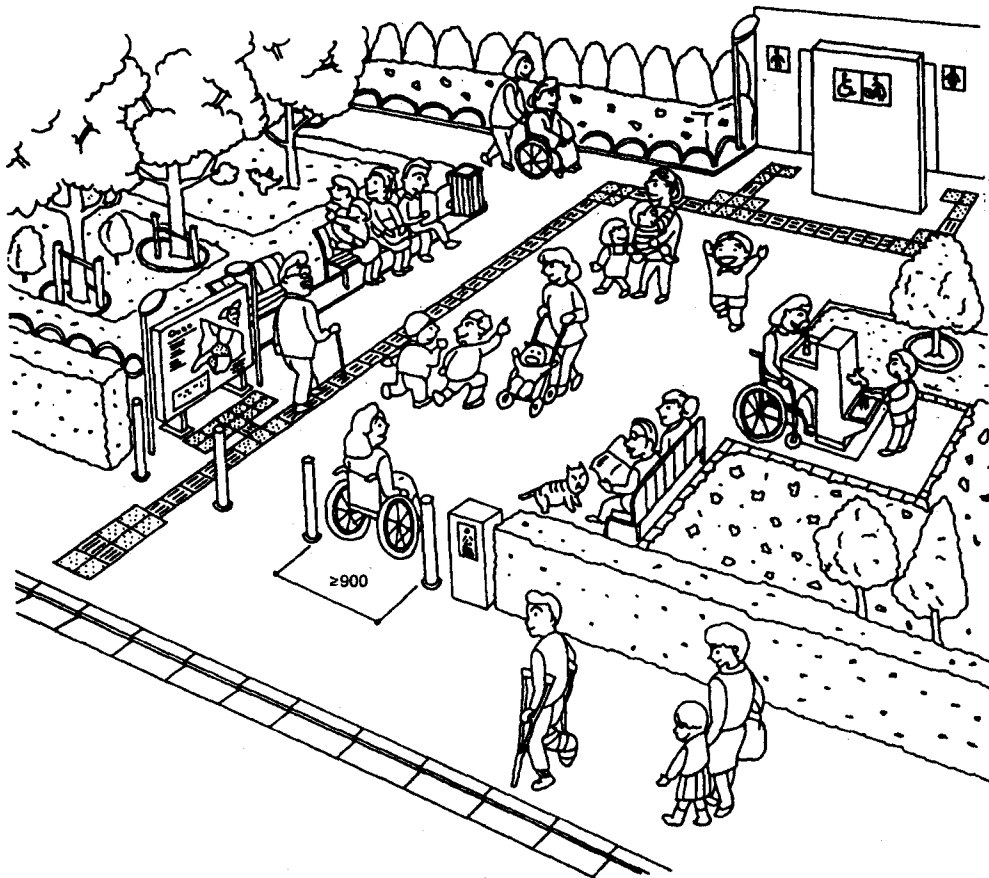

Park entrance/exit

Other Facilities

Counters

To make a counter easily accessible for a wheel chair user, allow a space about 700mm high and 350mm deep under the counter.

Water Fountains (Drinking)

Allow sufficient space around the water fountain to make it easily accessible for wheel chair users. Depending on the type of water fountain allow a space about 700 mm high and 350 mm deep under the fountain.

Telephones

Allow a space about 700 mm high and 350 mm deep under the telephone stand. The telephone receiver must be placed at a height of 110 cm or less.

Mailboxes

The mail slot must be located at a height of 1200 mm or less.

Vending Machines

The coin slot must be located at a height of 1200 mm or less.

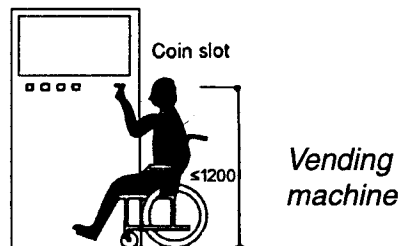
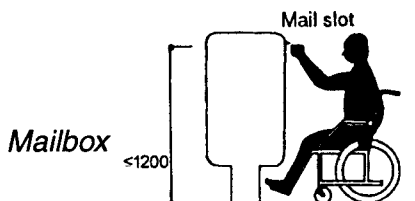
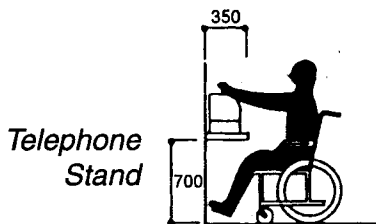
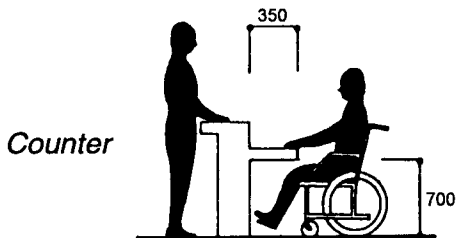

Design Elements Outside the Building

1. Kerb at Footpath
2. Road Crossing
3. Public Toilets
4. Bus Stops/Taxi Stand
5. Telephone Booth
6. Signages

Note:

Kerb At Foot Path

Signages

*

For details, refer Site Planning

*

For details, refer Signages in Design Elements Within The Building Premises.

Road Crossing

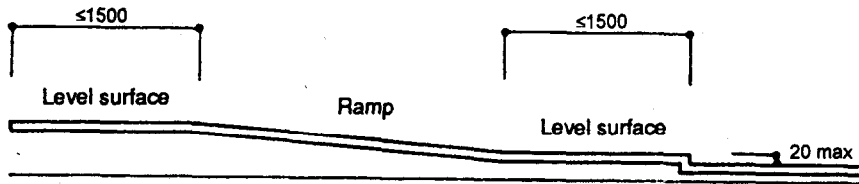

Cross section of graded level differences

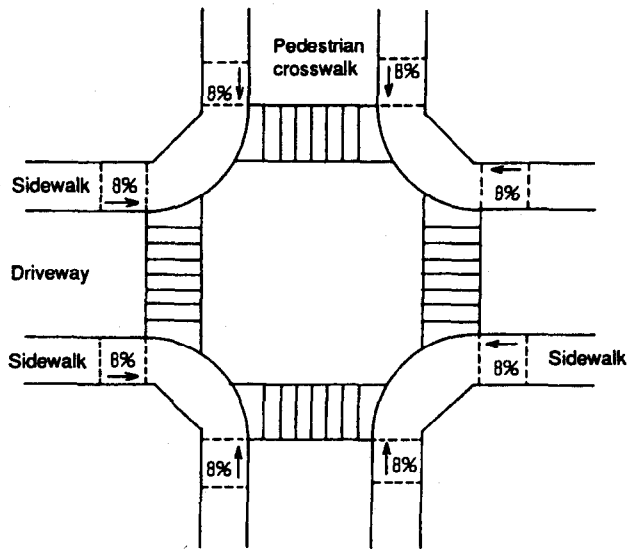

Sidewalk grading (at intersection)

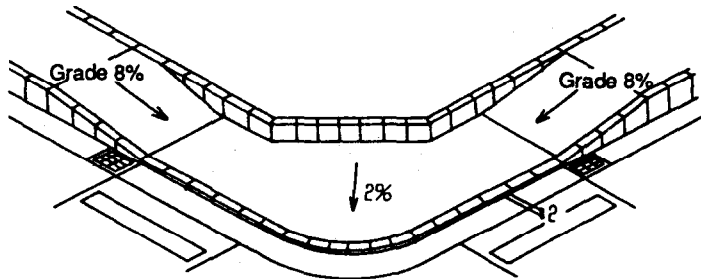

Sidewalk Fences

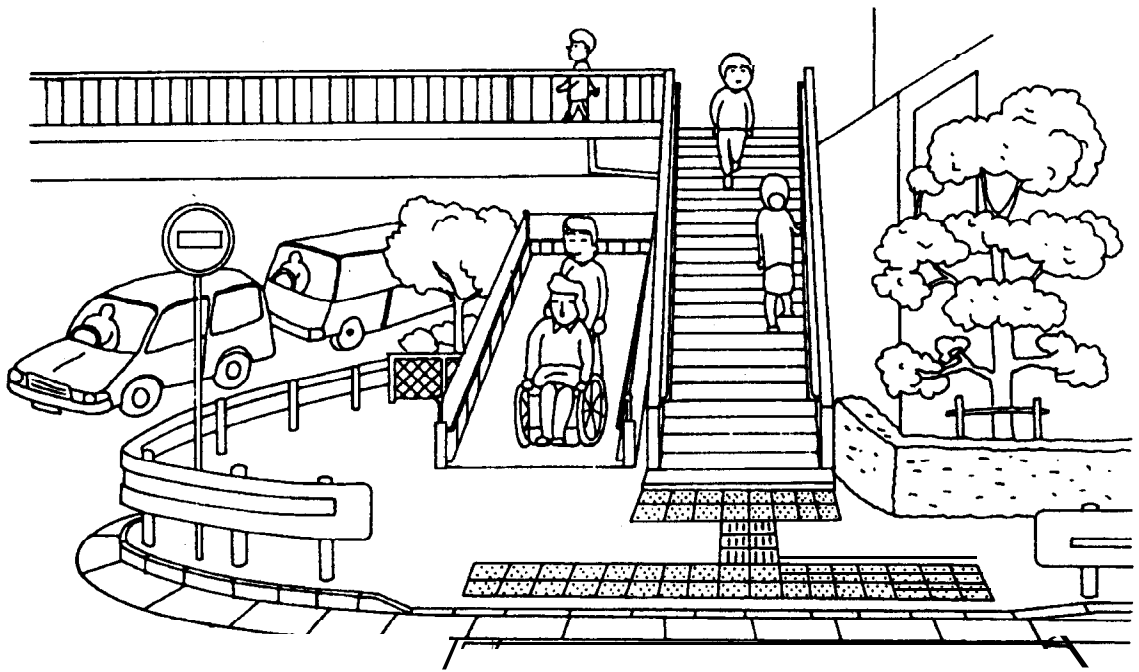

Pedestrian bridge and ramp

Public Toilets

The toilet bowl should preferably be a stool type.

At least one of the toilet bowls must have a handrail installed.

The door should, as a rule, be outward-opening.

The door lock must be easily operable. Also, an indication must be provided on the outside of the stall to show that the toilet is occupied.

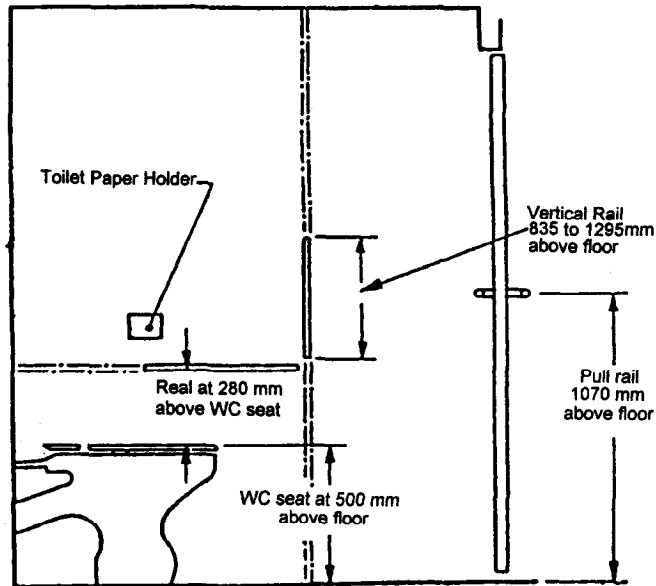

Side elevation of toilet stall

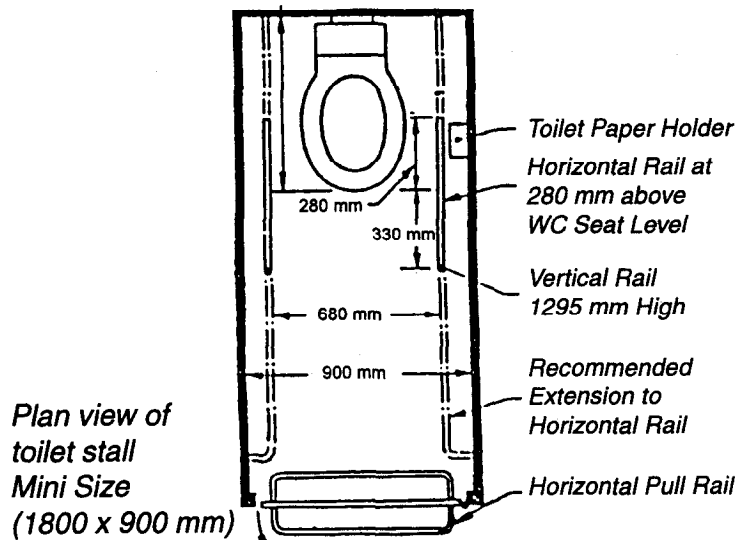

*Plan view of
toilet stall
Mini Size
(1800 x 900 mm)*

Bus Stops

- * Two rows of guiding blocks for persons with impaired vision should be provided 300 mm. away from the bus stop pole on the sidewalk.
- * The bus stop pole should be clearly visible after dark.
- * The bus stop area should be equipped with a roof and bench.

Example of guiding blocks for persons with impaired vision installed at bus stop

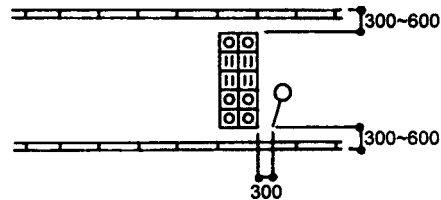

- * Information on the names of all stops along a bus route should be indicated inside the bus by displaying text in a suitable position. Preferably, this information should also be announced verbally.
- * Information on a route and its final destination should be displayed outside the bus in large text, especially on its front and side. This information should be illuminated by an internal light to make it readable in the dark.

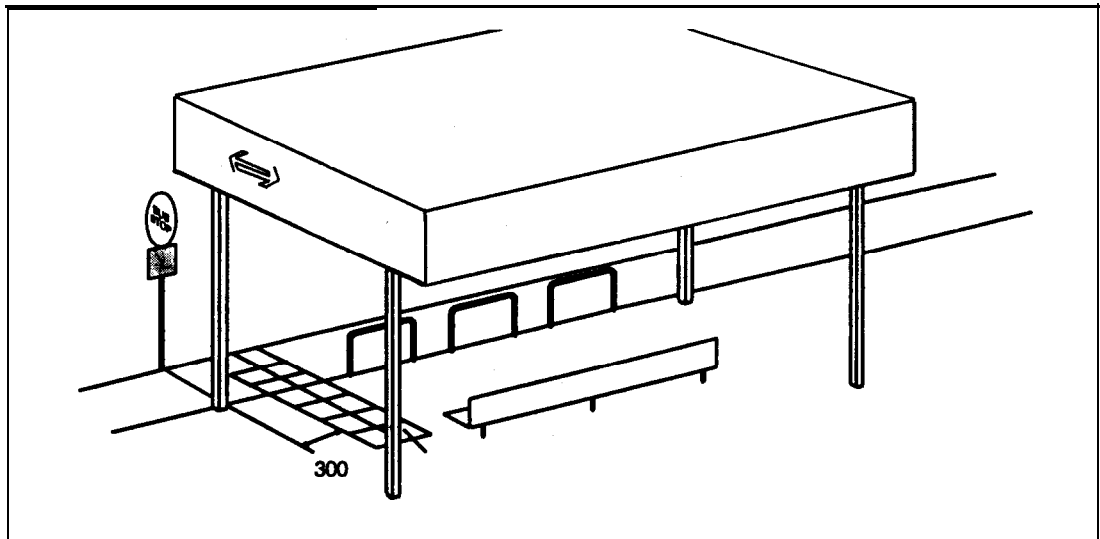

Guiding blocks for persons with impaired vision

Taxi Stand

Taxi Stand

- * Two rows of guiding blocks for person with impaired vision should be provided 300 mm. away from the taxi stand pole on the sidewalk.
- * The taxi stand pole should be visible after dark.
- * For wheelchair users to be able to approach a taxi easily, sudden level differences from the taxi stand to the road need to be eliminated.

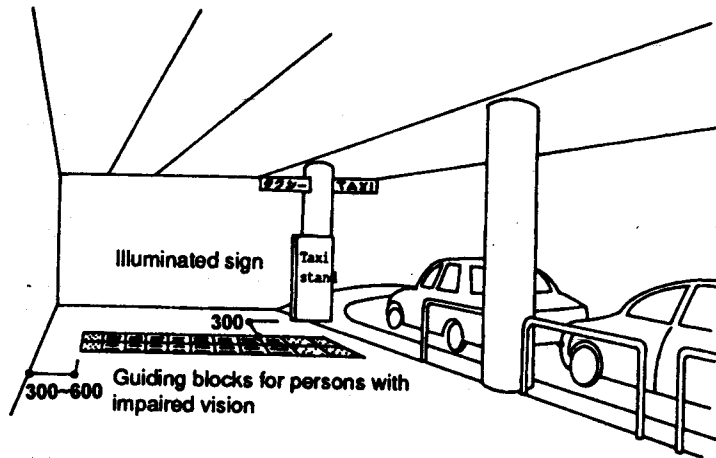

Taxi Stand

Taxi Interior

- * It is recommended that taxis be adapted to allow passengers to get in and out of them while remaining **seated** in their wheelchairs.

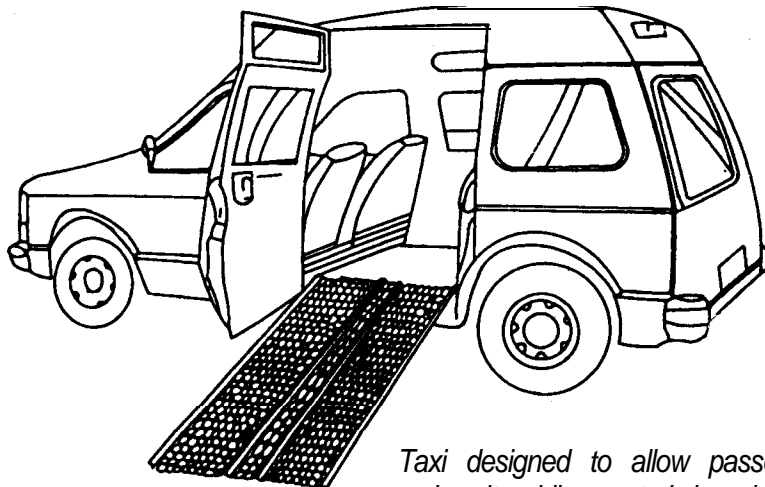

Taxi designed to allow passenger entry and exit while seated in wheelchair

Telephone Booth

- * Sufficient floor or ground space for a forward or parallel approach by a wheelchair user should be provided near telephone booths.
- * The highest part of a telephone should be within reach of a seated person.
- * Knee space should be provided under telephones.

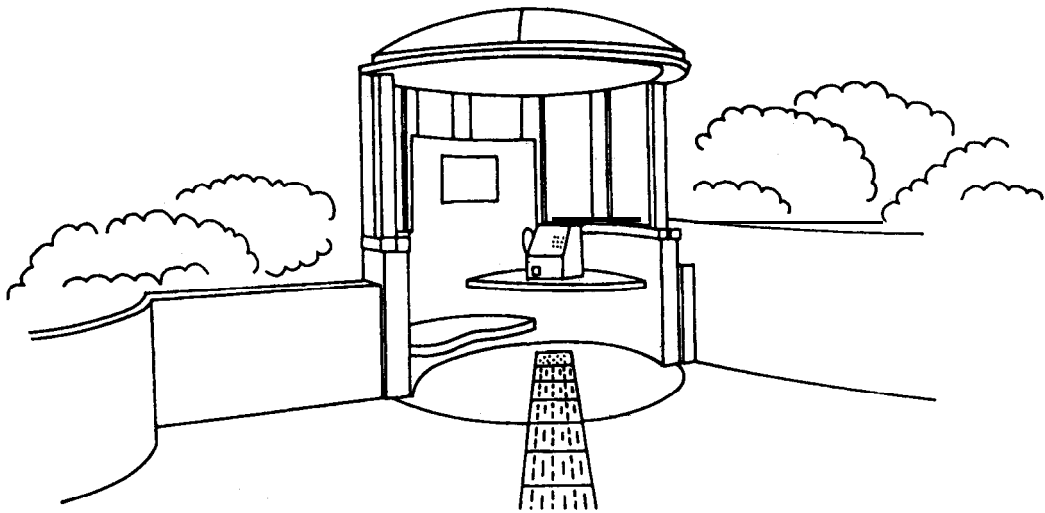

Telephone booth

Residential Buildings

Essential areas for barrier free design standards for disabled other than the general building design standards are as follows:

Street

Shopping area

Access to transportation

Kitchen

Bathroom

Bedrooms

Living rooms

Windows and the view

STREET

Before building any apartment house for the elderly and handicapped, it is advisable to note street conditions, access to transportation, proximity to shopping areas, and whether there are major obstacles between the apartment house and the shopping locations.

Both wheelchair users and elderly handicapped persons have a common need of hard, nonslip, even street surface. Avoid loose gravel and provide continuing common surface not interrupted by steps or sudden changes in level, and other obstructions such as manhole covers, light or telephone poles. The street should be marked with signages in braille and visual signages at appropriate height to indicate the shopping area, apartment blocks, bus stop, taxi stand.

SHOPPING AREA

It is not enough to design a barrier free building for the handicapped and elderly, one must also provide barrier free streets and shopping areas within the immediate vicinity if the residents are to be as self sufficient as they would like and could be.

There should not be any major crossing between the apartment block and shopping area. If unavoidable, some form of safe crossing, such as bridge or subway accessible by ramp and steps over or below the highway should be planned which people could get from' one side of the road to the other. The shops should be accessible with all essential barrier free design elements such as ramped approach along with stepped approach,. adequate space for landing, sufficiently wide corridor, signages, sliding or automatic door, guiding warning block, accessible counter, telephone booth, mail box, and toilet facilities.

ACCESS TO TRANSPORTATION

It is essential to accept that very few handicapped or elderly persons living in such a special housing are able to drive or have their own cars, because of their handicaps or age, or even for economic reasons. This means that both groups must rely on public transportation. The important components which are required to take care for easy access to transportation facilities are as below.

- * Safe crossing facilities for persons with wheel chair and with impaired vision by providing acoustic signal and installing a safety zone on a wide road.
- * Provision of kerb ramp at appropriate location at the footpath.
- * Provision of guiding block at the starting and ending of crossing.
- * Accessible bus stop/taxi stand (refer transportation, details or bus stop/taxi stand).
- * Accessible sub way/over bridge (refer transportation, details of over bridge).
- Accessible concourse, ticket booth of the railway station (refer transportation).

Kitchen

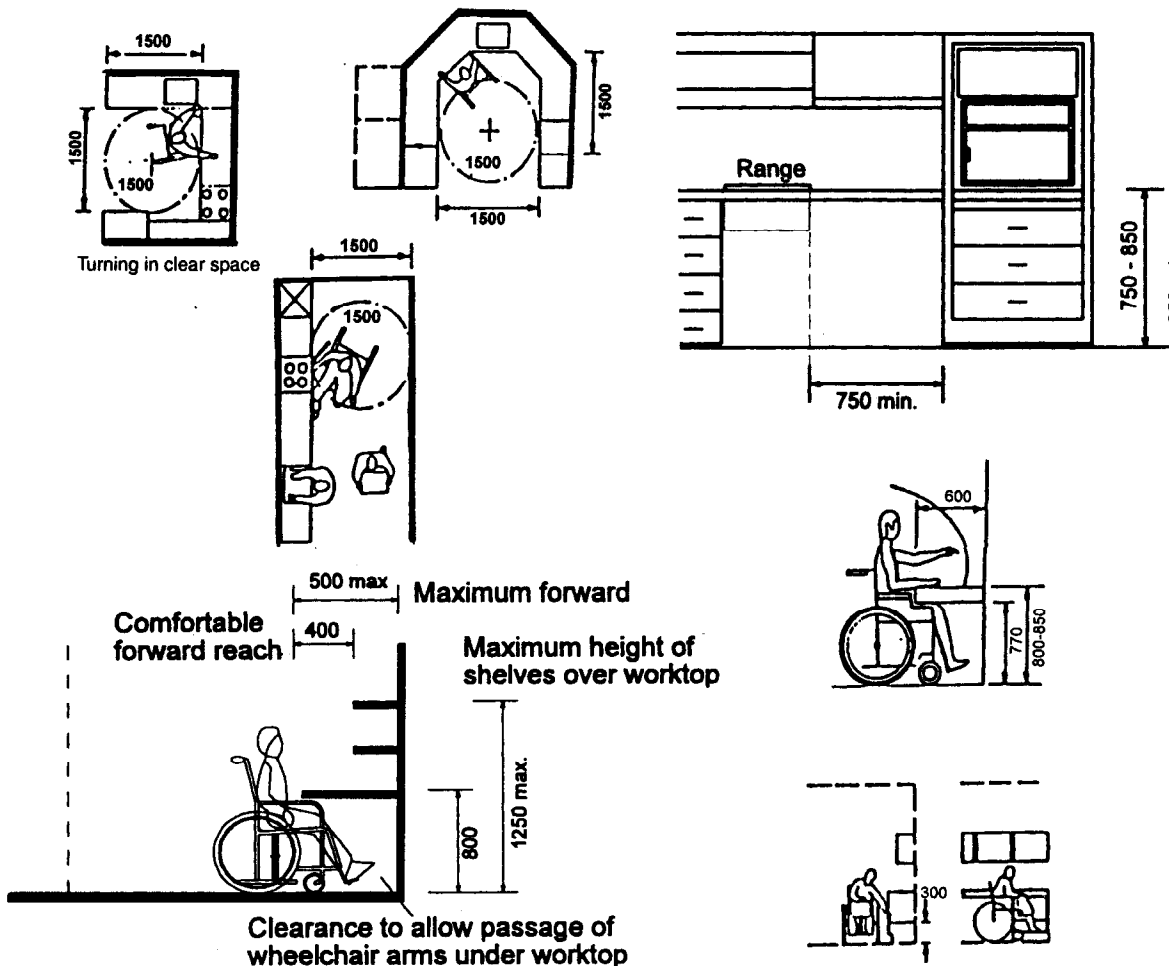

- * Floor space should allow easy wheelchair movement between worktop, sink and cooking stove. A 1500 mm min. width should be provided for wheelchair turns between counter and opposite wall.
- * Worktops, sinks, and cooking area should be at the same level at a height of 780 mm - 800 mm high from floor.
- * A knee room of 700 mm high should be provided under the sink.
- * Base cabinets storage space with hinged doors and fixed or adjustable shelves should be avoided. Base cabinets are most usable with drawers of various depth. Pullout vertical units at one or both sides of the work centres are desirable.
- * Maximum height of shelves over worktop is 1200 mm.
- * A min. gap of 400 mm. should be provided between the edge of work top and top shelves. Side reach for low shelf height should be 300 mm.

Living Room & Bed Room

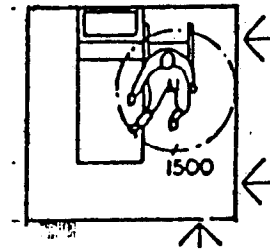
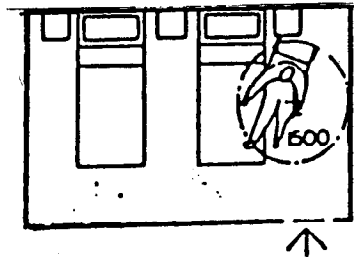
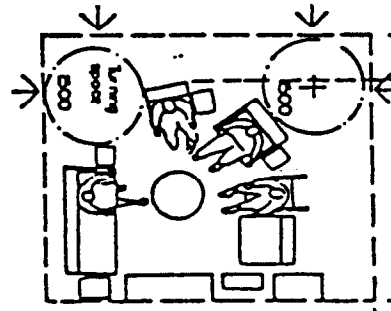
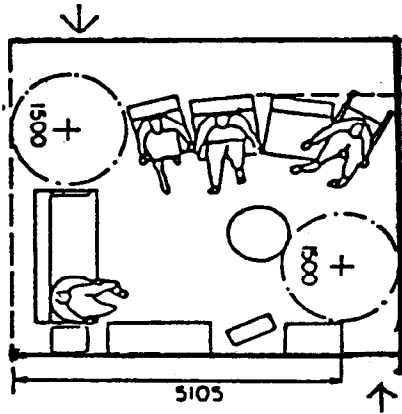

- * At least 1500 mm turning in space for wheel chair should be kept near all entry points to the living area.
- * A living dining combination is preferable to a kitchen dining combination.
- * A wheelchair requires at least 750 mm seating space at the dining table.

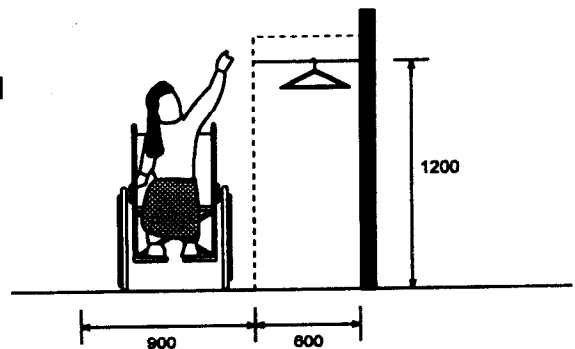
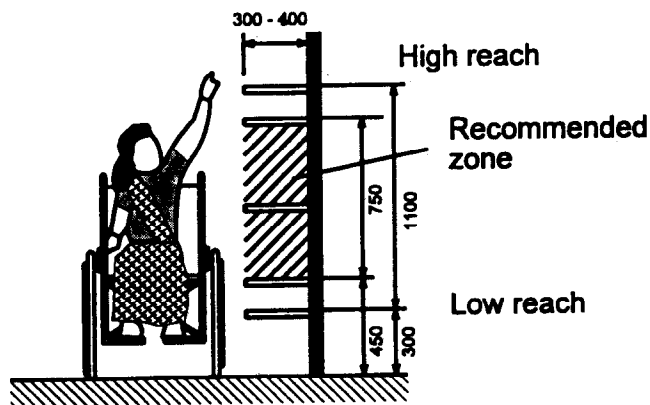

- * Sleeping- living room combinations are not recommended. Bed rooms for the wheelchair users need more floor area to provide wheelchair circulation.
- * The bedroom layout should be such that the bed should not be in a corner of a wall. At least 900 mm should be provided for a wheelchair from the side of the wall for access and there should be large enough space for transfer by a wheelchair user, or for a helper to assist in the transfer.'
- * The bed should be at a height from the ground that permits wheel chair turning under the bed.
- * A min. 900 mm width should be kept in front of bedroom closet and any other furniture.
- * Clothes hanger rod should be at a height between 1050 mm - 1200 mm. The max. and min. height of shelf should be 1400 and 300 mm, and the recommended zone is from 450 mm to 1200 mm.

Bathroom

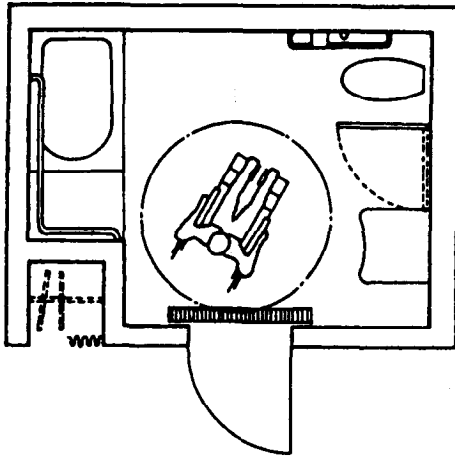

Plan view of bathroom (private)

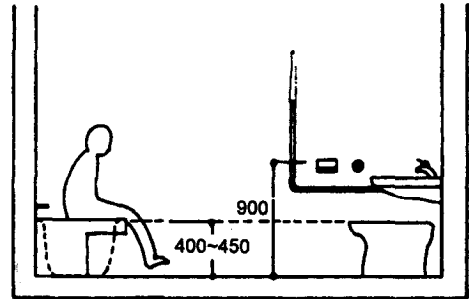

Side elevation of bathroom (private)

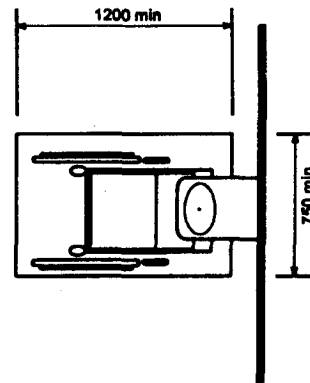
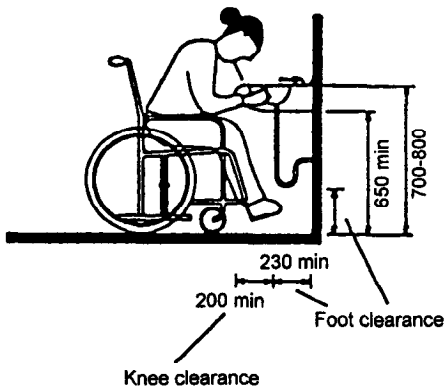

- * The basin should be installed at a height and position for convenient access by wheelchair users.
- * The basin should have appropriate knee clearance and foot clearance space for wheelchair users.
- * Sufficient clear space for wheelchair users should be provided in front of the basin.
- * The mirror should be so installed as to permit its use by wheelchair users.
- * Shower cubicles should have seats whose width and height facilitate easy transfer by wheelchair users.
- * Shower cubicles should have grab rails at a height and position that allows for easy gripping by wheelchair users.

- * Shower cubicles should have call buttons or other signals devices at a height and position easily reached in an emergency.
- * Sufficient space should be provided beside shower cubicles for transfer by wheelchair users.
- * Showerdoors, locks or catches should be of a type that can be opened from the outside in an emergency.
- * Shower doors should preferably be of a sliding or outward opening type.
- * These recommendations are relevant for communal bathing facilities for low-income households.

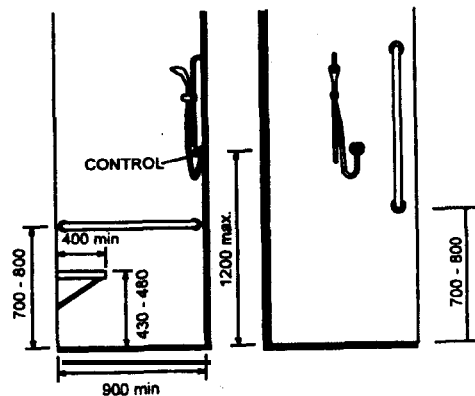
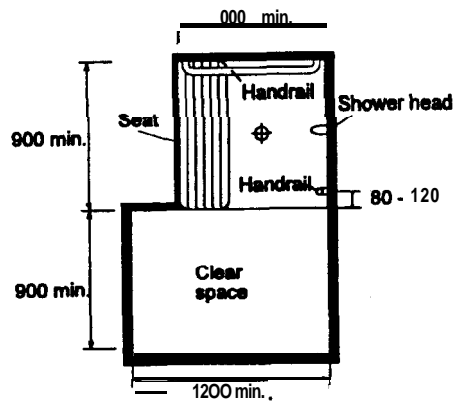

- * WC or toilet compartments should have enough floor space for wheelchair users to enter and exit.
- * The toilet bowl should be of a type (e.g. wall-hung) and in such a position as to permit easy approach by wheelchair users.
- * The seat of the toilet bowl should be at the correct height for wheelchair users.
- * WC compartments should have support rails at a position and height suitable for wheelchair users and other persons with physical disabilities. Upward-folding support bars are recommended to allow lateral transfer from a wheelchair.
- * A toilet paper dispenser should be so installed as to be easily used by a person with physical impairments sitting on the toilet.
- * Fittings, such as soap dispenser, electric hand dryer and mirror, should be low enough for a wheelchair user to use comfortably.
- * The wash basin should be at a height that is easily accessible for wheelchair users.
- * Lever-type taps should be installed to wash basins.
- * Floor finishes should be of non-slip material.
- * Doors should be either of the sliding or outward-opening type.
- * Locks to toilet doors or cubicles should be of a type that can be opened from outside in case of emergency.

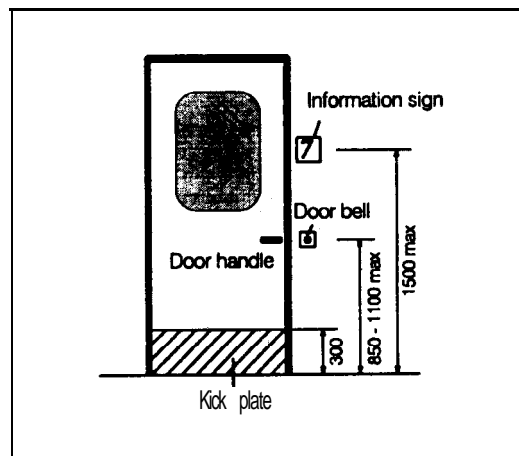

Guest House

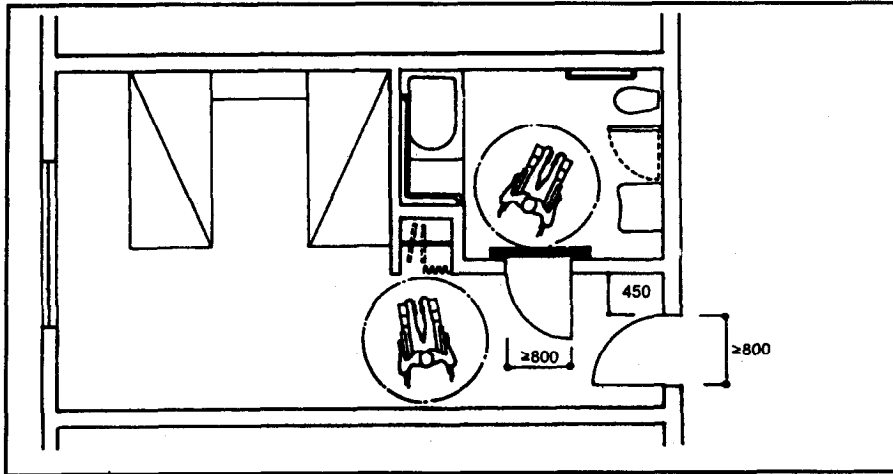

Plan view of guest room

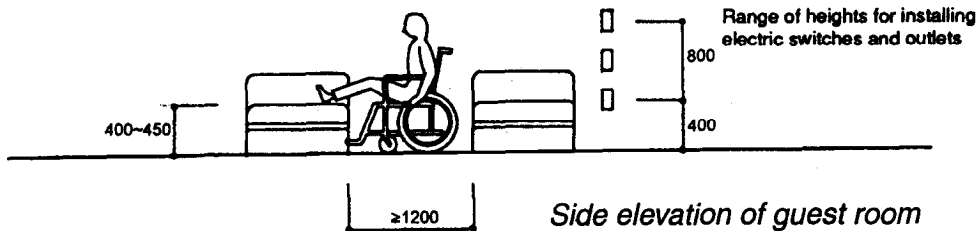

Side elevation of guest room

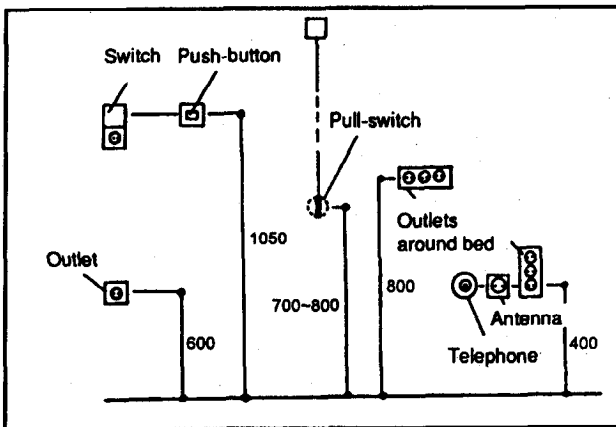

Electric switch and outlet heights

Adequate space is required for a wheelchair user to transfer from the wheelchair to a toilet seat.

For details of Bathroom and Bedroom, refer details of Bed Room & Bathroom of Residential Buildings.

Auditorium

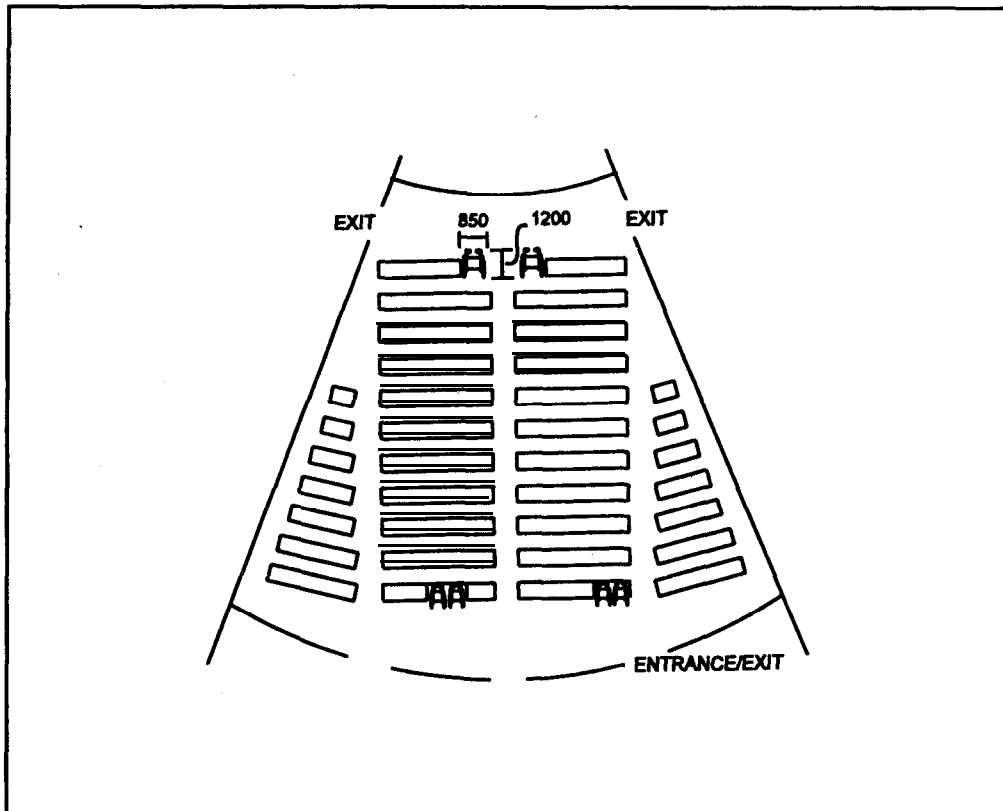

- * Applies to wheelchair spaces in auditoria, assembly halls, theatres and similar facilities.
- * Accessible seating space should be provided in a variety of locations to give persons with physical disabilities a choice.

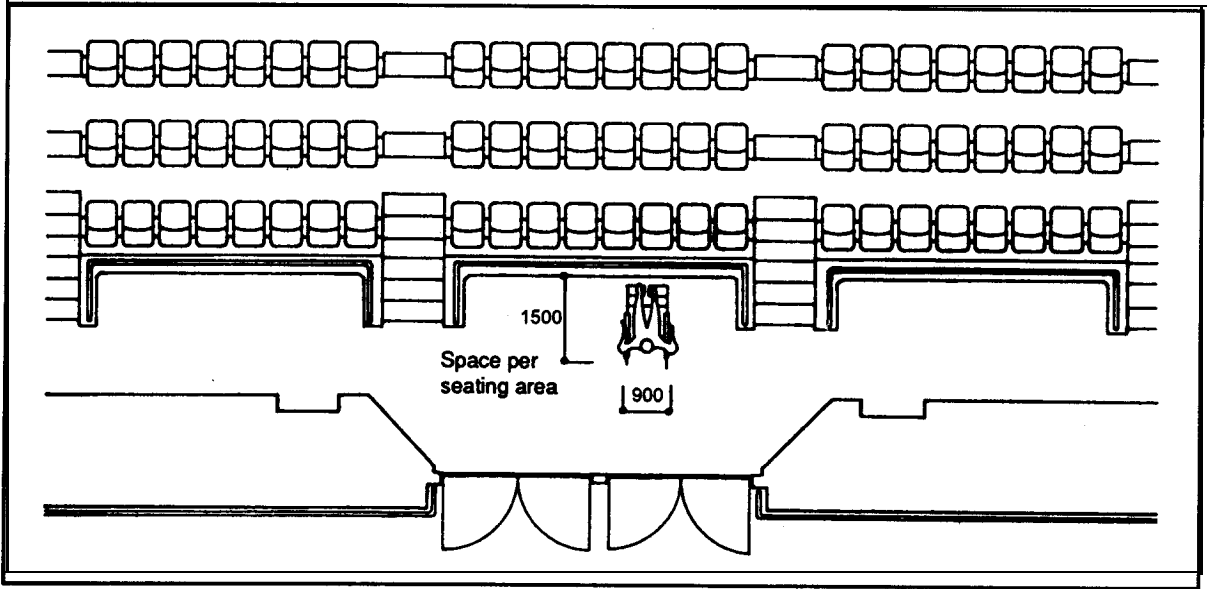

Plan view of guest seating arrangement

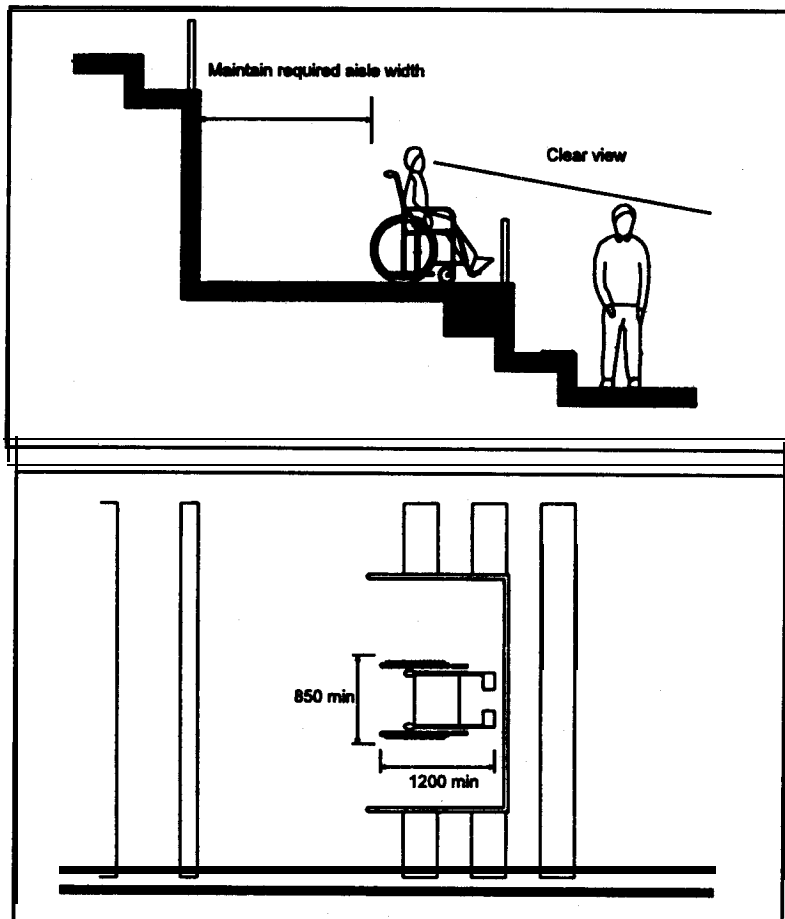

Parks

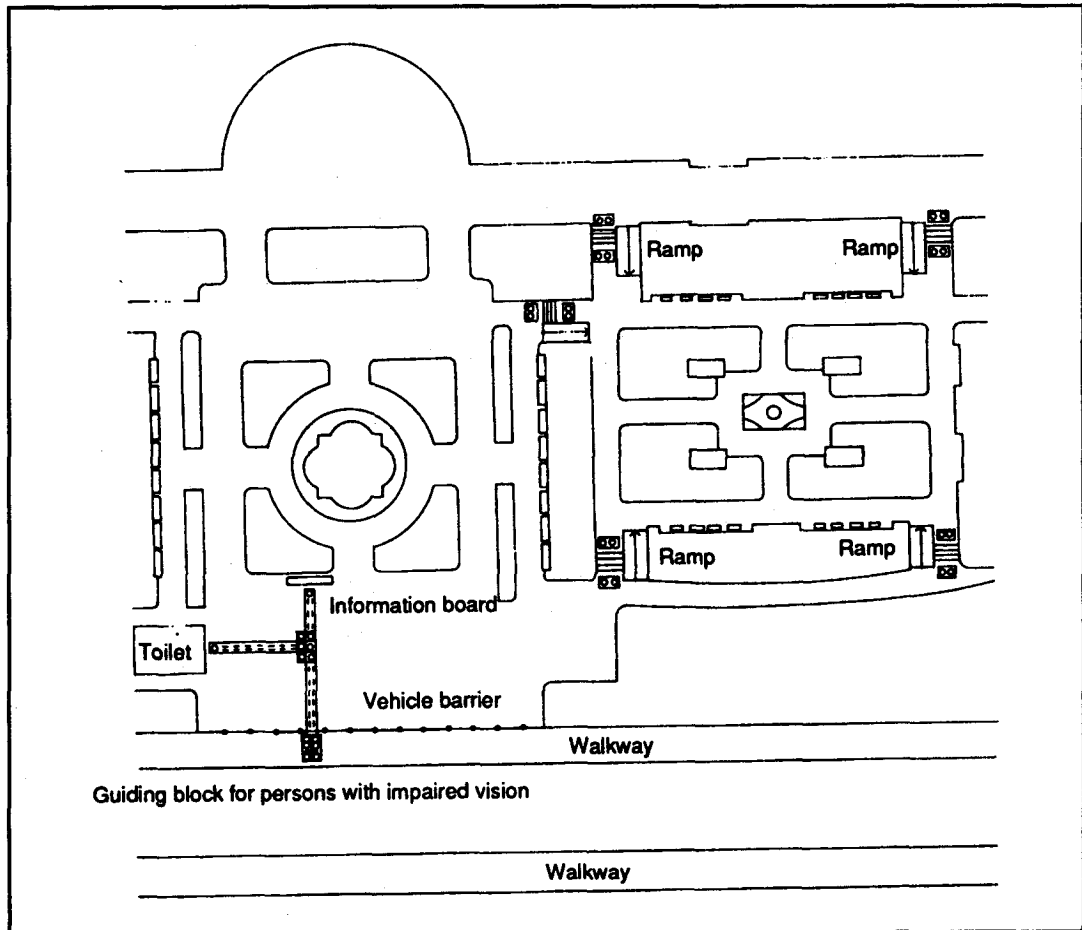

Park road

- * These should be no difference in level around an approach to a park and/or park roads. If a level difference is unavoidable, a ramp or a staircase plus a ramp is needed.

A level landing should be provided before and after the change in level.

- For ramp, see the guidelines for "Ramps".

- For stairs, see the guidelines for "Steps and Stairs".

- * Paved surfaces should be made of a non-slip material.
- * At locations where there is a difference in level, such as stairs, the surface material should be changed using a colour contrast scheme and guiding blocks.

- * Approaches and pathways should be wide enough for wheelchair users (min. 900 mm. with regular passing places 1800 mm. wide).
- * Drainage ditches should not be constructed in park road areas. If a drainage ditch has to be constructed, a ditch cover should be provided.
- * Slots in ditch/drain covers must be narrow enough so as not to risk crutches or the tyres of wheelchairs being stuck.
- * An information board with information about the facility should be provided for persons with impaired hearing. The board should be designed to be easily legible by using sufficiently large text size, distinct contrast and illumination. The information should also be in Braille.
- * Benches, dustbins and drinking fountains should be installed with adequate space around them for wheelchair users to manoeuvre.
- * Benches should be installed along the side of park roads.
- * Guiding blocks should be provided for persons with a visual impairment.

Restaurant

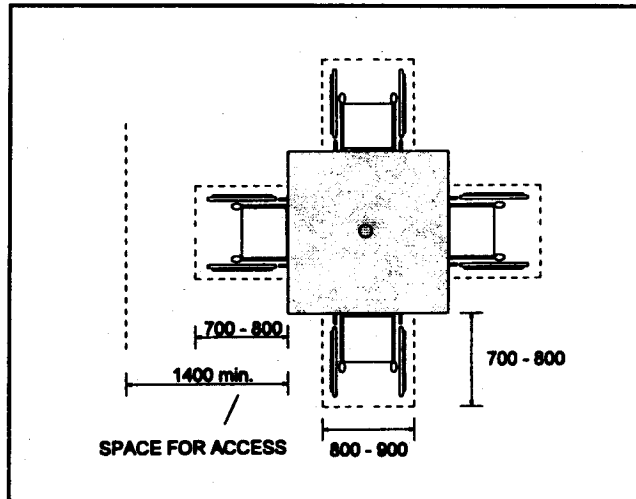

Access to table

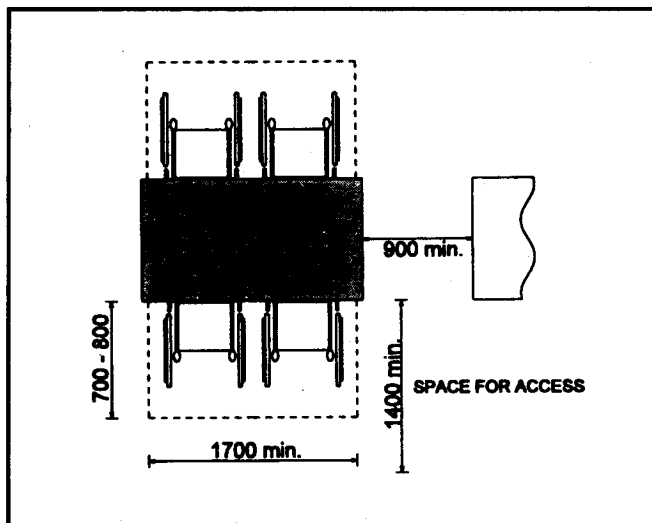

- * A space should be provided for wheelchair users at tables.
- * A space should be provided for wheelchair user for access to and from the tables.

Railway Stations

Approach to Station

- * The approach should not have a difference in level. If a level difference is unavoidable, install a ramp or a ramp plus staircase.
(The ramp should comply with the guidelines for “Ramps” and the stair should comply with those for “Steps and Stairs”).

Paved Surfaces

- * Pathways should be constructed of non-slip material. At places where there is a difference in level, such as where staircases meet floors, it is desirable that the appearance of the surface material be changed using colour contrast both immediately before and after that area.
- * The approach pathway should have guiding blocks for persons with impaired vision (see “Guiding Blocks”).
- * If the approach pathway is parallel to a road for vehicles, enhance the safety of pedestrians by installing guard rails.

Platform Entrances and Exits

- * The station entrance/exit should not have a difference in level. If a level difference is unavoidable, install a ramp or a ramp plus staircase.
(The ramp should comply with the guidelines for “Ramps” and the stair should comply with those for “Steps and Stairs”).

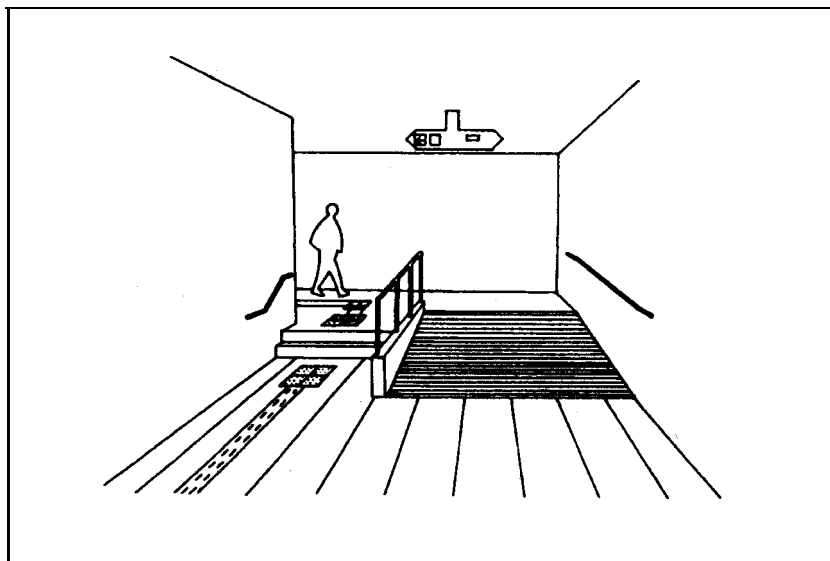

- * It is desirable that space be marked out near the entrance/exit for vehicles carrying wheelchair users.

(For other details about parking lots, see "Parking Space").

Reservation or Information Counters

- * Reservation or information counters should have unobstructed approaches for wheelchair users.
- * Counter heights should not be in excess of 850 mm.

Concourse

- * The width of the concourse should be at least 1800 mm.
- * The concourse should not have a difference in level. If a level difference is unavoidable, install a ramp or a ramp plus staircase.
(The ramp should comply with the guidelines for "Ramps" and the stair should comply with those for "Steps and Stairs").
- * The floor surface of a concourse should be made of a non-slip material. At places, where there is a difference in level such as stairs, it is desirable that the appearance of the surface material be changed using colour contrast.
- * Ensure that columns, signboards, and other fixtures do not protrude from wall surfaces (see "Protruding Objects" Ref. Page No. 33).
- * Install guiding blocks on the concourse for persons with impaired vision (see "Guiding Blocks" Ref. Page No. 46).

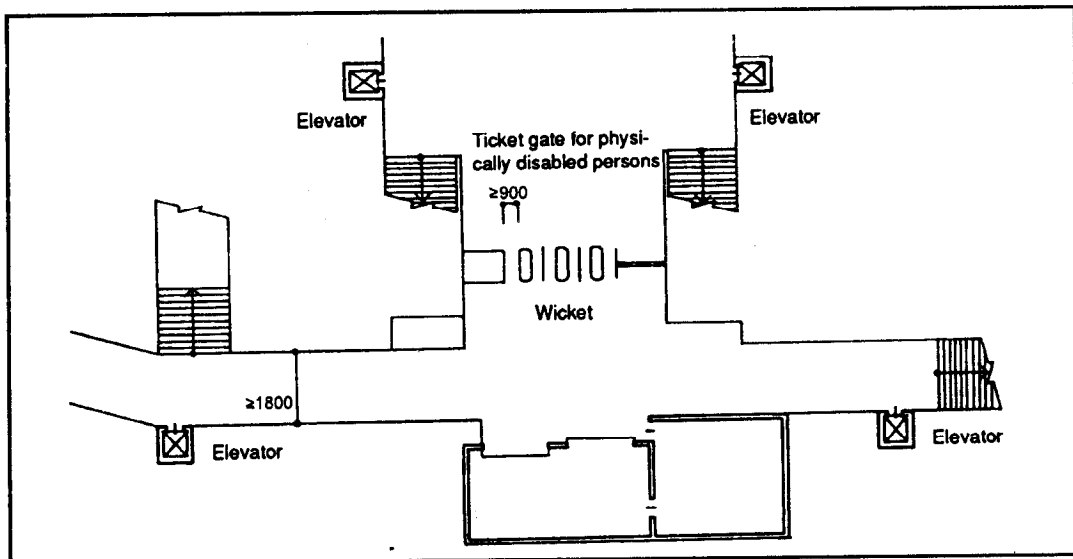

Concourse

Stairs

- * For details, see the guidelines for “Steps and Stairs”.

Lifts (Elevators)

- Install a lift (elevator) **as a** means to enable passengers with disabilities to move between floors.
- * For the lift (elevator), install two guiding blocks for persons with impaired vision 300 mm. away from the call button.
- * For other details, see “Lifts”.

WC

- * Install a toilet and washstand suitable for use by wheelchair users and other passengers.

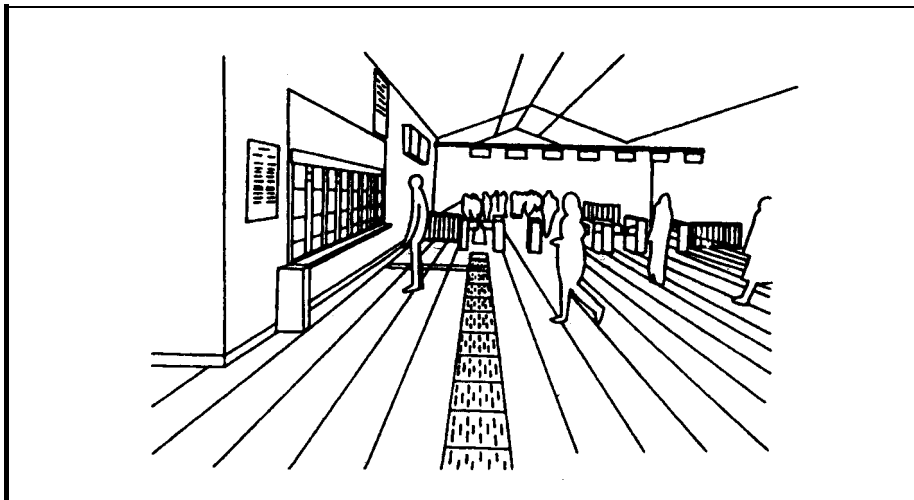

Guiding blocks to ticket gates for persons with "impaired vision"

Ticket Gates

- * At least one of the ticket gates should be wide enough to allow wheelchair users to pass through easily.
- * One of the ticket gates should have a continuous line of guiding blocks for persons with impaired vision.
- * For other details, see “Guiding Blocks”.

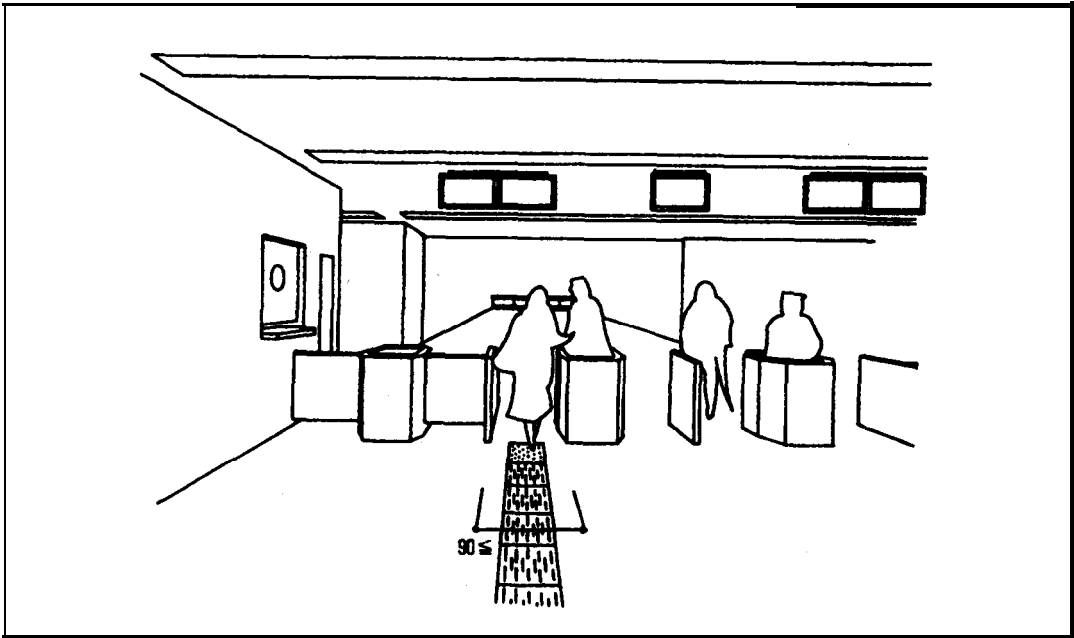

Ticket gates

Ticket Vending Machines

- * The coin slot should be at a suitable height for easy insertion of coins by wheelchair users.
- * A knee recess beneath the ticket vending machines should be provided.
- * Install guiding blocks for persons with impaired vision 300 mm. **away** from the ticket vending machine.
- * The fare buttons, cancel buttons and other information buttons should be written in Braille or in a distinct relief pattern.

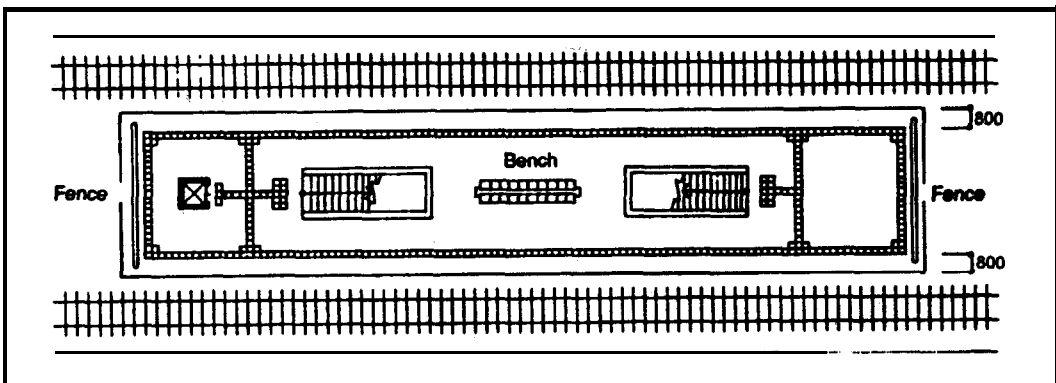

Plan view of platform

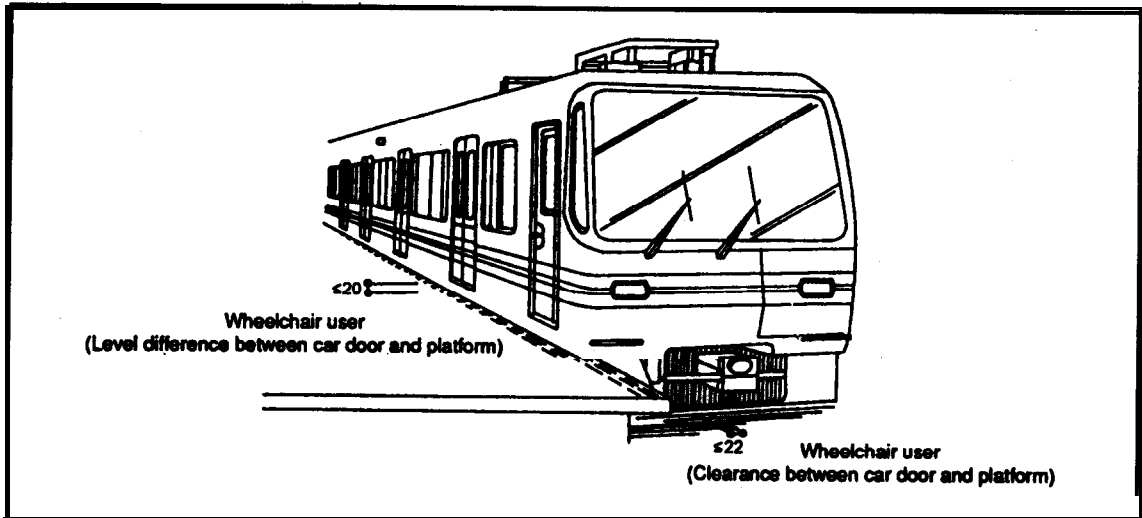

Level difference and clearance between car door and platform

Platforms

- * The platform should have one row of dotted guiding blocks for persons with impaired vision, 800 mm. or more from the edge.
- * The paved surface of the platform must be made with a non-slip material.
- * Stairs, kiosks and dustbins on the platform must not hinder the clear passage of persons with impaired vision and wheelchair users.
- * A bench should be installed on the platform, having guiding block around it.

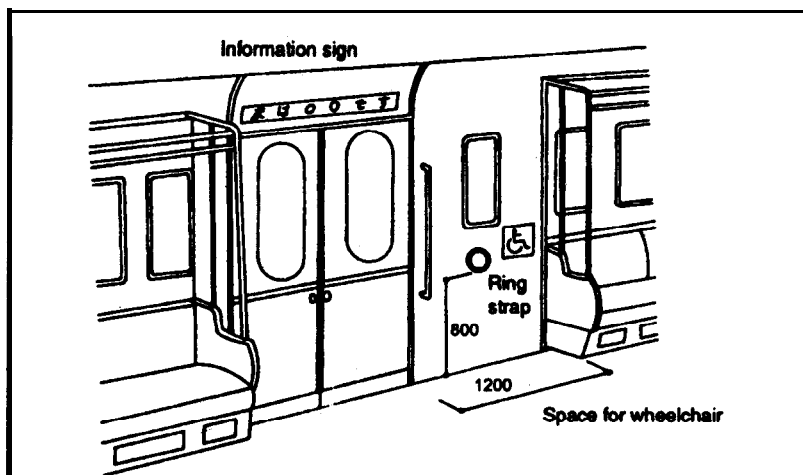

Wheelchair space and information sign inside the car

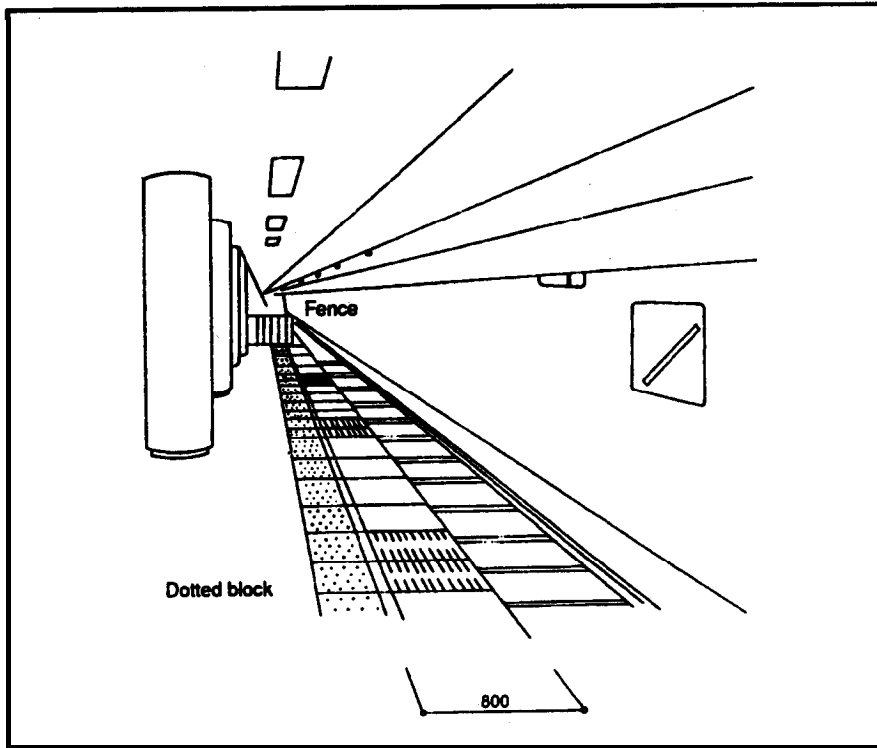

Platform

Railway and subway car doors

- Car doors should be wide enough for wheelchair users (minimum 900 mm).
- * The gap between car doors and the platform should be reduced to an absolute minimum.

Aisles

- * Aisles should be wide enough for the passage of wheelchair users.

Wheelchair Space

- * A space for a wheelchair should be made available at the side of the door.
- * The space should be indicated inside and outside the car by using the universally recognized symbol for wheelchair accessibility.
- * Install a ring-strap or other appropriate safety grip for wheelchair users to hold on to.

Information

- * The information board should be made easily readable by using sufficiently large text size, distinct contrast and illumination.
- * It is desirable that in addition to a printed version of train schedule, table of fares and other travel information also be in Braille.
- * For hearing impaired persons an electronic sign board of appropriate size & height should be displayed on each platform at conspicuous location for all announcements made by the railways.

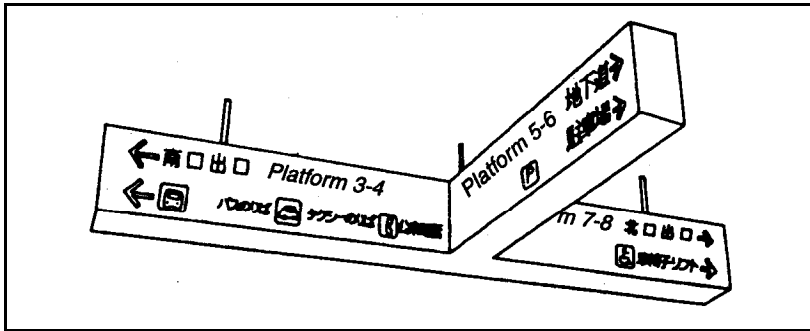

Information boards in concourse

Information signs and announcements

- * Install a map of train routes
- * Announce and provide in each car a visual display of the names of stations en route.

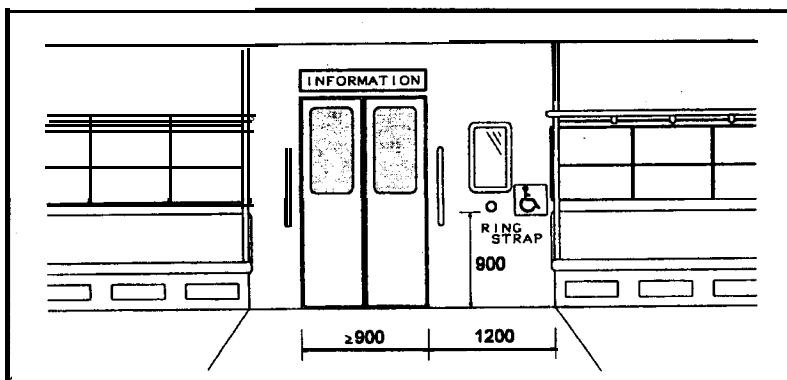

Wheelchair space inside the car

Seats

- * An appropriate numbers of designated seats for passengers with disabilities and for elderly people should be provided near doors.

Model building bye-laws to provide facilities for physically handicapped persons.

BYE-LAWS

1. SHORT TITLE, EXTENT & COMMENCEMENT

- 1.1 These bye-laws shall be annexed to the (City) Municipal Bye-laws.
- 1.2 They shall extend to a whole Municipality of (City).
- 1.3 They shall come into force after months from the date of their publication in the official Gazette.

2. DEFINITIONS

- 2.1 **Non-ambulatory Disabilities** :- Impairments that, regardless of cause or manifestation, for all practical purposes, confine individuals to wheelchairs.
- 2.2 **Semi-ambulatory Disabilities** :- Impairments that cause individuals to walk with difficulty or insecurity. Individuals using braces or crutches, amputees, arthritics, spastics, and those with pulmonary and cardiac ills may be semi-ambulatory.
- 2.3 **Hearing Disabilities** :- Deafness or hearing handicaps that might make an individual insecure in public areas because he is unable to communicate or hear warning signals.
- 2.4 **Sight Disabilities** :- Total blindness or impairments affecting sight to the extent that the individual, functioning in public areas, is insecure or exposed to danger.
- 2.5 **Wheel Chair** :- Chair used by Disabled people for mobility. The standard size of wheel chair shall be taken as 1050 mm X 750 mm.

3. SCOPE

These bye-law are applicable to all buildings and facilities used by the public. It does not apply to private & public residences.

4. SITE DEVELOPMENT

Level of the roads, access paths and parking areas shall be described in the plan along with specification of the materials.

- 4.1 **Access Path/Walk Way** :- Access path from plot entry and surface parking to Building entrance shall be minimum of 1800 mm. wide having even surface without any steps. Slope, if any, shall not have gradient greater than 5%. Selection of

floor material shall be made suitably to attract or to guide visually impaired persons (limited to coloured floor material whose colour and brightness is conspicuously different from that of the surrounding floor material or the material that emit different sound to guide visually impaired persons hereinafter referred to as "guiding floor material" (Annexure-I). Finishes shall have a non slip surface with a texture traversable by a wheel chair. Curbs wherever provided should blend to a common level.

- 4.2 Parking :- For parking of vehicles of handicapped people the following provisions shall be made:
- a) Surface parking for two Car Spaces shall be provided near entrance for the physically handicapped persons with maximum travel distance of 30.0 meter from building entrance.
 - b) The width of parking bay shall be minimum 3.6 meter.
 - c) The information stating that the space is reserved for wheel chair users shall be conspicuously displayed.
 - d) Guiding floor materials shall be provided or a device which guides visually impaired persons with audible signals or other devices which serves the same purpose shall be provided.

5. BUILDING REQUIREMENTS

The specified facilities for the buildings for physically handicapped persons shall be as follows:

1. Approach to plinth level
2. Corridor connecting the entrance/exit for the handicapped.
3. Stair-ways
4. Lift
5. Toilet
6. Drinking water

5.1 Approach to plinth level :- Every building should have at least one entrance accessible to the handicapped and shall be indicated by proper signage. This entrance shall be approached through a ramp together with the stepped entry.

5.1.1 Ramped Approach :- Ramp shall be finished with non slip material to enter the building. Minimum width of ramp shall be 1800 mm. with maximum gradient 1:12, length of ramp shall not exceed 9.0 meter having 800 mm high hand rail on both sides extending 300 mm. beyond top and bottom of the ramp. Minimum

gap from the adjacent wall to the hand rail shall be 50 mm.

5.1.2 **Stepped Approach** :- For stepped approach size of tread shall not be less than 300 mm. and maximum riser shall be 150 mm. Provision of 800 mm. high hand rail on both sides of the stepped approach similar to the ramped approach.

5.1.3 **Exit/Entrance Door** :- Minimum clear opening of the entrance door shall be 900 mm. and it shall not be provided with a step that obstructs the passage of a wheel chair user. Threshold shall not be raised more than 12 mm.

5.1.4 **Entrance Landing** :- Entrance landing shall be provided adjacent to ramp with the minimum dimension 1800 mm x 2000 mm. The entrance landing that adjoin the top end of a slope shall be provided with floor materials to attract the attention of visually impaired persons (limited to coloured floor material whose colour and brightness is conspicuously different from that of the surrounding floor material or the material that emit different sound to guide visually impaired persons hereinafter referred to as "guiding floor material" (Annexure-I). Finishes shall have a non slip surface with a texture traversable by a wheel chair. Curbs wherever provided should blend to a common level.

5.2 **Corridor connecting the entrance/exit for the handicapped** :- The corridor connecting the entrance/exit for handicapped leading directly outdoors to a place where information concerning the overall use of the specified building can be provided to visually impaired persons either by a person or by signs, shall be provided as follows:

- a) 'Guiding floor materials' shall be provided or devices that emit sound to guide visually impaired persons.
- b) The minimum width shall be 1500 mm.
- c) In case there is a difference of level slope ways shall be provided with a slope of 1:12.
- d) Hand rails shall be provided for ramps/slope ways.

5.3 **Stair-ways** :- One of the stair-ways near the entrance/exit for the handicapped shall have the following provisions:

- a) The minimum width shall be 1350 mm.
- b) Height of the riser shall not be more than 150 mm and width of the tread 300 mm. The steps shall not have abrupt (square) nosing.
- c) Maximum number of risers on a flight shall be limited to 12.
- d) Hand rails shall be provided on both sides and shall extend 300 mm. on the top and bottom of each flight of steps.

5.4 Lifts :-Wherever lift is required as per bye-laws, provision of at least one lift shall be made for the wheel chair user with the following cage dimensions of lift recommended for passenger lift of 13 persons capacity by Bureau of Indian Standards.

Clear internal depth : 1100 mm.

Clear internal width : **2000** mm.

Entrance door width : 900 mm.

- a) A hand rail not less than 600 mm. long at 1000 mm. above floor level shall be fixed adjacent to the control panel.
- b) The lift lobby shall be of an inside measurement of 1800 mm x 1800 mm. or more.
- c) The time of an automatically closing door should be minimum 5 seconds and the closing speed should not exceed 0.25 Meter/Sec.
- d) The interior of the cage shall be provided with a device that audibly indicates the floor the cage has reached and indicates that the door of the cage for entrance/exit is either open or closed.

5.5 Toilets :- One special W.C. in a set of toilet shall be provided for the use of handicapped, with essential provision of wash basin near the entrance for the handicapped.

a) The minimum size shall be 1500 mm x 1750 mm.

b) Minimum clear opening of the door shall be 900 mm. and the door shall swing out.

c) Suitable arrangement of vertical/horizontal handrails with 50 mm. clearance from wall shall be made in the toilet.

d) The W.C. seat shall be 500 mm. from the floor.

5.6 Drinking Water :- Suitable provision of drinking water shall be made for the handicapped near the special toilet provided for them.

5.7 Designing for Children :- In the buildings meant for the pre-dominant use of the children, it will be necessary to suitably alter the height of the handrail and other fittings & fixtures etc.

Explanatory Notes

GUIDING/WARNING FLOOR MATERIAL

The floor material to guide or to warn the visually impaired persons with a change of colour or material with conspicuously different texture and easily distinguishable from the rest of the surrounding floor materials is called **guiding or warning floor material**. The material with different texture gives audible signals with sensory warning when a person moves on this surface with walking stick. The guiding/warning floor material is meant to give the directional effect or warn a person at critical places. This floor material shall be provided in the following areas:-

- a) The access path to the building and to the parking area.
- b) The landing lobby towards the information board, reception, lifts, stair-cases and toilets.
- c) Immediately at the beginning/end of walkway where there is a vehicular traffic.
- d) At the location abruptly changing in level or beginning/end of a ramp.
- e) Immediately in front of an entrance/exit and the landing.

PROPER SIGNAGE

Appropriate identification of specific facilities within a building for the handicapped persons should be done with proper signages. Visually impaired persons make use of other senses such as hearing and touch to compensate for the lack of vision. Whereas visual signals benefit those with hearing disabilities.

Signs should be designed and located so that they are easily legible by using suitable letter size (not less than 20 mm. high). For visually impaired persons, information board in braille should be installed on the wall at a suitable height and it should be possible to approach them closely. To ensure safe walking there should not be any protruding sign which creates obstruction in walking. Public Address System may also be provided in busy public areas.

The symbols/informations should be in contrasting colour and properly illuminated because people with limited vision may be able to differentiate amongst primary colours. International symbol mark for wheel chair as shown below be installed at the lift, toilet, staircase, parking areas etc., that have been provided for the handicapped.

Bibliography

1. Code of practice for "Access for the Disabled to Buildings" - British Standard Institution BS 5810 : 1979.
2. Code of practice for design of housing for the convenience of the disabled people BS 5619 : 1978.
3. Designing for the disabled by Selwyn Goldsmith, A RIBA of London : 2nd Edition, revised and expanded in 1967.
4. Designing a public convenience for the disabled. S. Goldsmith, P.J.R. Nichois, B. Rostance, J. Angel, L. Angel.
5. Planning for the disabled, Interim report of Norwich Survey of Wheel Chair users - S. Goldsmith.
6. London for the disabled, F. Bruce, Lockhart, Ward Lock, London.
7. Access to Public Buildings for the disabled. Ministry of Public Buildings and works, Ministry of Health. H.M.S.O., London.
 - a. Barrier Free Environments, Edited by Michael J. Bednar, University of Virginia.
9. Architectural Barriers for the Handicapped. A survey of the law in the United States, R. Dantona, B. Tessler, Rehabilitation Literature N.S.C.C.A. Chichago.
10. American Standard Specification for making buildings and facilities accessible to and usable by the physically handicapped. American Standard Association, New York, 1961.
11. Design of buildings to permit their use by the physically handicapped, T.J. Nugent, New Building Research, U.S.A.
12. The American Institute of Architects, Architectural Graphic Standards - Ramsey / Sleeper.
13. Time saver standards for Site Planning Joseph De Chiara & Lee E. Koppelman.
14. Time saver standards for residential development Joseph De Chiara.
15. Australian standard Code of Practice for Design Rules for Access by the Disabled as 1428 - 1977 Published by Standards Association of Australia.
16. Indian Standard Recommendations for Buildings and Facilities for the Physically Handicapped IS : 4963 - 1968,1988.

17. Rehabilitation Centre for Physically Handicapped Children - M.L. Buttan. (B. Arch Thesis, S.P.A., New Delhi)
18. Rehabilitation Centre for Physically Handicapped-Lucknow - Mona Swaroop. (B. Arch. Thesis S.P.A. New Delhi)
19. Needs of the handicapped in buildings International Organization for Standardization.
20. Design for Accessibility by Robert James Sorensen.
21. Creating a safe and accessible city, Yokohama City Guidelines for Improving Barrier - Free Access in the Urban Environment (The city of Yokohama, Japan).
22. Promotion of Non-handicapping Physical Environments for Disabled persons : Guidelines, United Nations.
23. Norms and Space Standards for Physically Disabled People. Housing and Development - Board Singapore.
24. Building Design for handicapped and aged persons by council on Tall Buildings and Urban Habitate.
25. "Transportation for the Handicapped - The Politics of full Accessibility" -- Traffic Quarterly, April, 1982. Fielding J Gordon
26. Disability : Challenges Vs Responses. Ali Baquer & Anjali Sharma

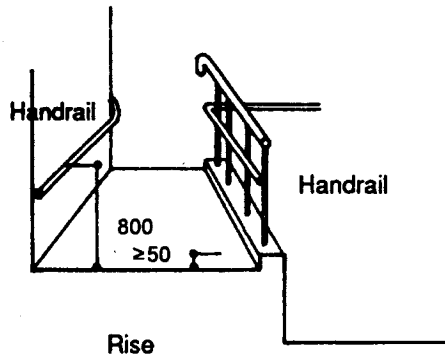

CROSS SECTION OF RAMP

- * When climbing a ramp in a wheelchair, the upper limbs must bear the burden of propelling the body up the ramp.
- * When descending a ramp in a wheelchair, especially on steep ramps, there is a possibility of the wheelchair running out of control because the user must manually control the speed.
- * Prevent the installation of steep ramps.
 - (a) Make sure the grade of a ramp is a moderate rise of 10 mm to each 120 mm of travel.
 - (b) Provide a flat surface 1500 mm or more in length at the top and bottom of the ramp for a wheelchair to pause and prevent it from going out of control.

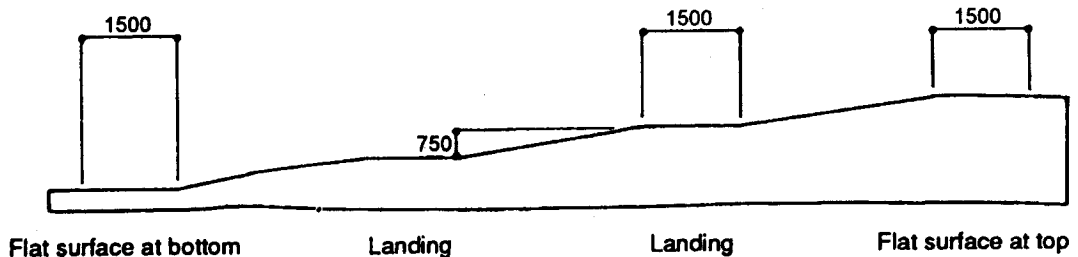

Cross Section of ramp

Stepped Approach :- For stepped approach size of tread shall not be less than 300 mm. and maximum riser shall be 150 mm. Provision of 900 mm high hand rail on both sides of the stepped approach similar to the ramped approach.